

WOOD SPECIES: \_\_\_\_\_  
 WOOD FINISH: \_\_\_\_\_  
 PLEASE ADVISE WOOD SPECIES AND WOOD FINISH. REFER TO C/S CATALOG FOR OPTIONS.

METAL FINISH: \_\_\_\_\_  
 PLEASE REFER TO C/S CATALOG FOR AVAILABLE METAL FINISH OPTIONS.

QTY. REQ'D	UNIT HGT.	BASE HGT.	FINISHED HGT.

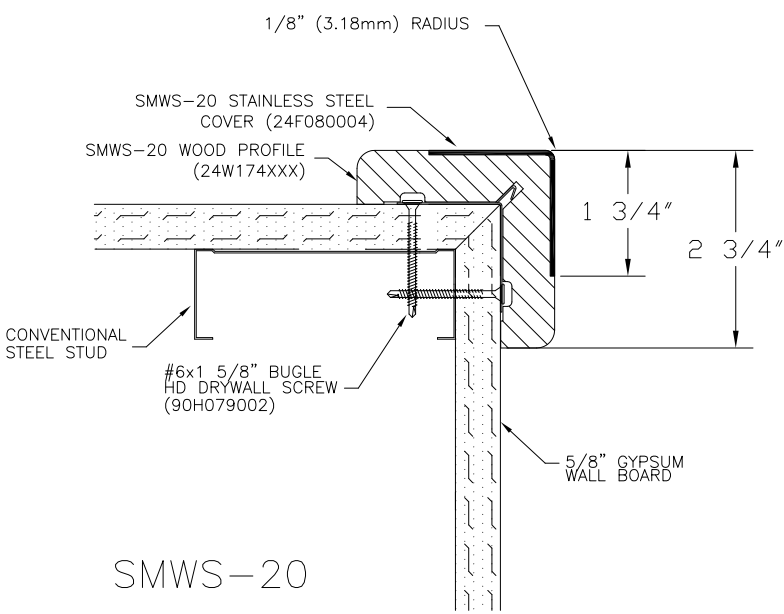

SMWS-20

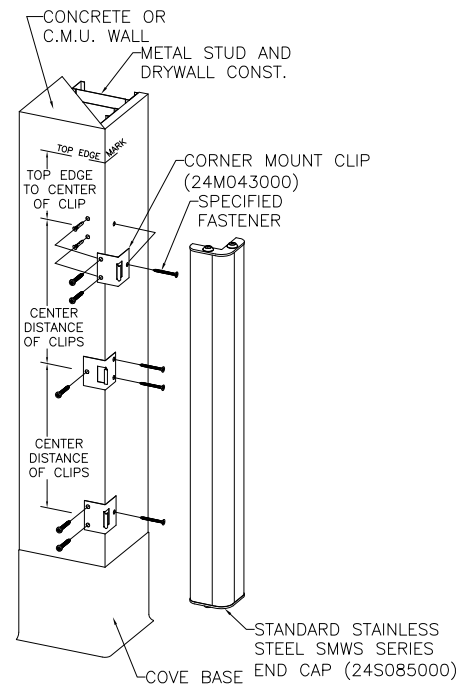

IF OPTIONAL SMWS SERIES WOOD END CAP IS REQUIRED PLEASE ADVISE (24W259XXX)

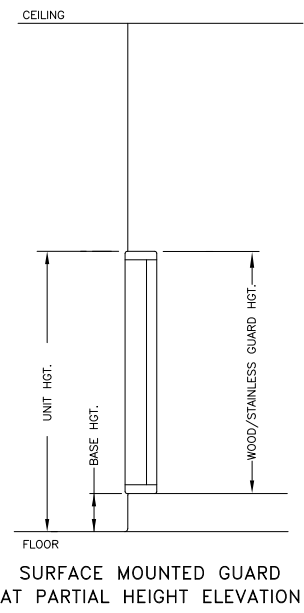

WALL CONDITION	SPECIFIED FASTENER	DRILL DIAMETERS		PART NUMBER
		WALL	RETAINER	
STEEL STUD/GYPSUM WALL WOOD STUD/GYPSUM WALL	#6 X 1-5/8" BUGLE HD. SMS	N/A	7/64"	90H079002
CONCRETE/CONC. BLOCK	{ AF-6 PLASTIC ANCHOR #10 X 1-1/2" PHILLIPS PAN HD. SMS }	15/64"	9/32"	90H039004 90H189002

 <p><b>Construction Specialties™</b>          6696 Route 405 Highway, Muncy PA 17756          (800) 233-8493 • Fax (570) 546-4692 • www.c-sgroup.com</p>	PROJECT:		REV. :
	LOCATION:		F&F:
	CUSTOMER:		SHEET OF
	AGENT:		JOB NO.
	DWG. BY:	DATE:	