

COLOR: _____
 COLOR TO BE SELECTED FROM ONE OF C/S
 STANDARD COLORS

QTY. REQ'D	UNIT HEIGHT	ANGLE	RET. LENGTH	COVER LENGTH

1. Establish corner guard height requirement. Cut the retainer pieces 5/8" (15.9mm) less than the overall height dimension.
2. Install the retainer pieces 1/4" (6.4mm) above the cove base, or finished floor, and set back from the corner the amount specified in the table below. See sketch for where the dimension applies to the retainer. Fasten utilizing the required mounting hardware noted on reverse.
3. Align one (1) endcap with the bottom of the two (2) modified retainer sections and secure into position using the specified fasteners. Make sure the endcap abuts the ends of the retainer sections.
4. Repeat the procedure to install the top endcap if required.
5. Cut the Acrovyn guard 1/8" (3.2mm) longer than the retainer.
6. Complete the installation by snapping the Acrovyn cover onto the retainer. Align one leg of the cover with one leg of the retainer and snap the cover into position by applying pressure towards the opposite leg of the retainer.

NOTE: MATERIAL MUST REACH 65°F MIN TO 75°F MAX 24 HOURS PRIOR TO INSTALLATION. THIS IS ESSENTIAL TO MINIMIZE EXPANSION AND CONTRACTION OF THE MATERIAL.

Angle	Dimension "A"		
	Decimal Inches	Fractional Inches	Millimeters
45	1.657	1 21/32	42.088
50	1.748	1 3/4	44.399
55	1.830	1 53/64	46.482
60	1.900	1 29/32	48.260
65	1.970	1 31/32	50.038
70	2.020	2 1/64	51.308
75	2.052	2 3/64	52.121
80	2.086	2 5/64	52.984
85	2.110	2 7/64	53.594
90	Standard Retainer		
95	2.126	2 1/8	54.000
100	2.132	2 9/64	54.153
105	2.154	2 5/32	54.712
110	2.182	2 3/16	55.423
115	2.219	2 7/32	56.363
120	2.241	2 1/4	56.921
125	2.265	2 17/64	57.531
130	2.285	2 9/32	58.039
135	2.300	2 5/16	58.420
140	2.310	2 5/16	58.674
145	2.318	2 21/64	58.877
150	2.325	2 21/64	59.055

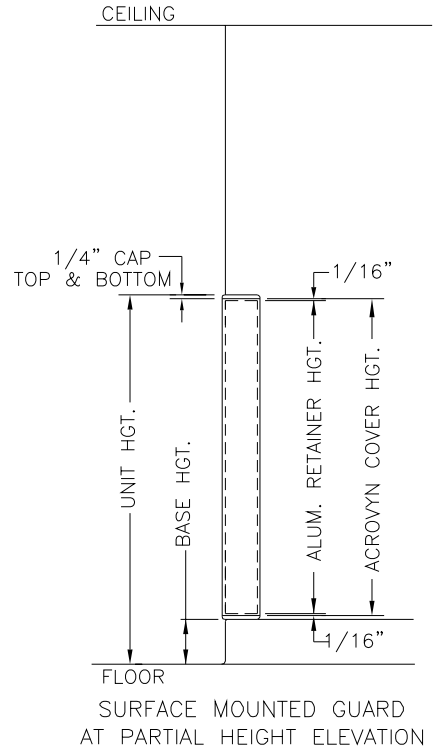
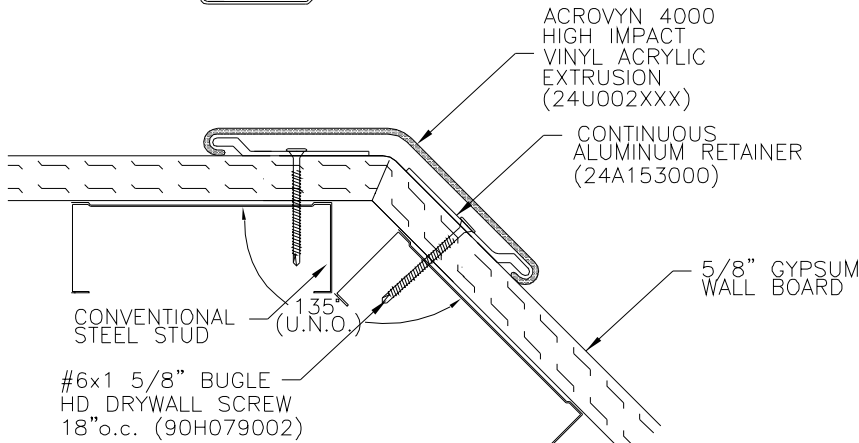
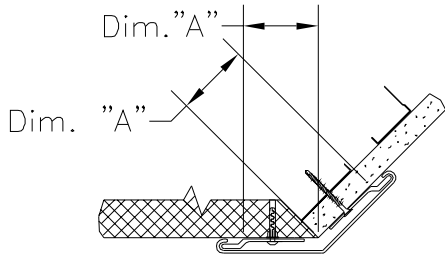
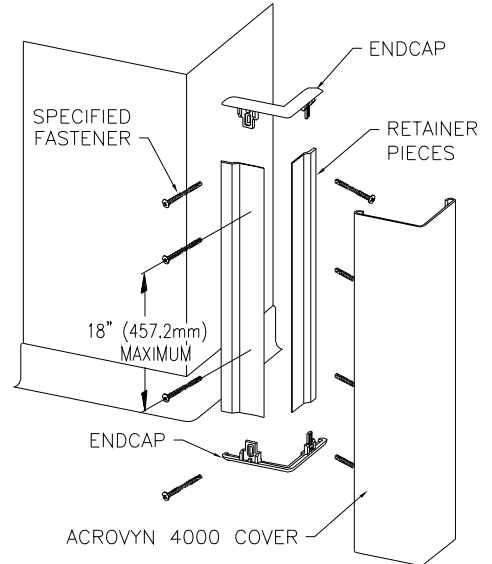

SM-20M N

ANGLES ONLY AVAILABLE BETWEEN 45° - 160°

PART NUMBERS BY MODEL				
MODEL NUMBER	ALUM. RETAINER	END CAP	GUARD	
SM-20M	24A153000	24I071XXX	24U002XXX	
WALL CONDITION	SPECIFIED FASTENER	DRILL DIAMETERS		PART NUMBER
		WALL	RETAINER	
STEEL STUD/GYPSUM WALL WOOD STUD/GYPSUM WALL	#6 X 1-5/8" BUGLE HD. SMS	N/A	7/64"	90H079002
CONCRETE/CONC. BLOCK	{ AF-6 ALLIGATOR ANCHOR { #10 X 1-1/2" PHILLIPS PAN HD. SMS }	15/64"	9/32"	90H039004
				90H189002
	{ AD44 ABSLF POP RIVET { #8SAE FLAT WASHER STL PLATED }	N/A	5/32"	90H018011 90H010003

 <p>Construction Specialties™ 6696 Route 405 Highway, Muncy PA 17756 (800) 233-8493 • Fax (570) 546-4692 • www.c-sgroup.com</p>	PROJECT:	REV.:
	LOCATION:	F&F:
	CUSTOMER:	SHEET:
	AGENT:	JOB NO.
	DWG. BY:	DATE: