

COLOR: _____

(COLOR TO BE SELECTED FROM ONE OF C/S STANDARD COLORS.)

TOTAL
L/F REQ'D

END
CAPS

O.S.
REQ'D

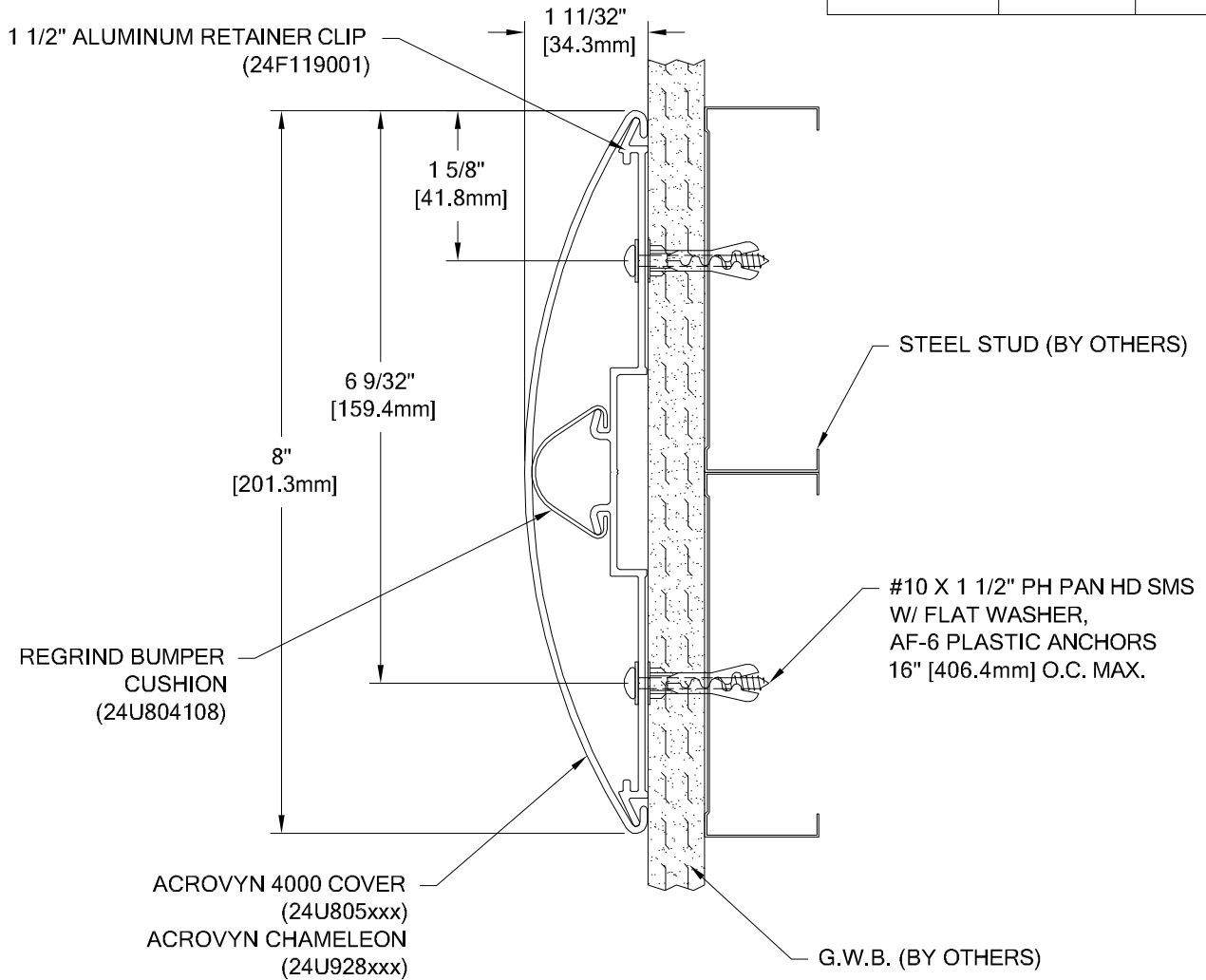

SCR-80N ACROVYN 4000

WALL CONDITION	SPECIFIED FASTENER	DRILL DIAMETERS		C/S PART NUMBER
		WALL	RETAINER	
STEEL STUD/GYPUSM WALL	#10 X 1 1/2" PHILLIPS PANHEAD SMS 1/4" FLAT WASHER STEEL PLATED SAE AF-6 PLASTIC ANCHOR	1/4"	1/4"	90H189002 90H007003 90H039004
CONCRETE/CONC. BLOCK	#10 X 1 1/2" PHILLIPS PANHEAD SMS 1/4" FLAT WASHER STEEL PLATED SAE AF-6 PLASTIC ANCHOR	1/4"	1/4"	90H189002 90H007003 90H039004
WOOD STUD/GYPSUM WALL	#9 X 2 1/4" WAFER HD PH DRYWALL SCREW 1/4" FLAT WASHER STEEL PLATED SAE	N/A	N/A	90H421002 90H007003

 <p>Construction Specialties™ 6696 Route 405 Highway, Muncy PA 17756 (800) 233-8493 • Fax (570) 546-4692 • www.c-sgroup.com</p>	PROJECT:	REVISION:
	JOB NO.:	F&F:
	CUSTOMER:	
	REP:	DATE:
	DRAWN BY:	SHEET NO: