

1. ESTABLISH CORNER GUARD HEIGHT REQUIREMENT. ALL CLEAR POLYCARBONATE CORNER GUARDS ARE PROVIDED IN THE LENGTHS AS LISTED BELOW.
2. PREPARE OUTSIDE CORNER FOR GUARD INSTALLATION BY REMOVING ANY OIL OR DUST CONTAMINATION USING "ACROVYN INTERIORS" CLEANER.
3. INSTALL THE CORNER GUARD BY ALIGNING THE BOTTOM OF THE CORNER GUARD WITH THE TOP OF THE COVE BASE OR FINISH FLOOR AND MOVING THE GUARD INTO POSITION ALONG THE APEX OF THE WALL SURFACE AND CORNER GUARD.
4. COMPLETE INSTALLATION BY SECURING THE CORNER GUARD INTO POSITION USING THE APPROPRIATE FASTENERS.

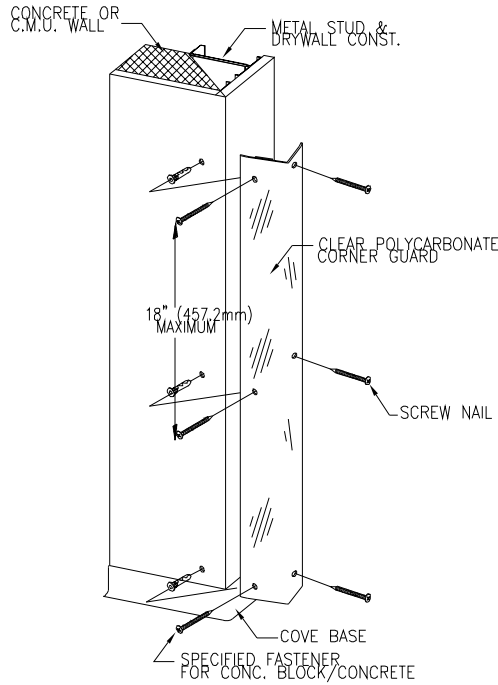

QTY. REQ'D	HGT. REQ'D

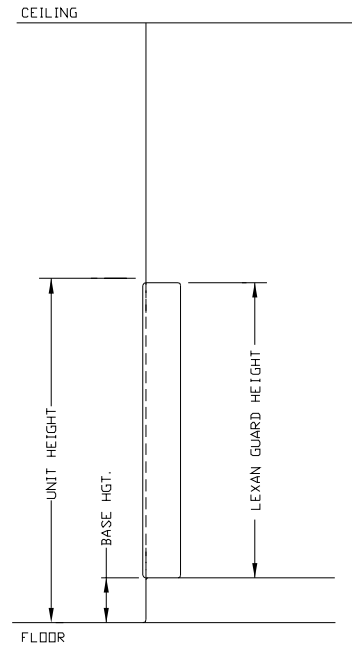
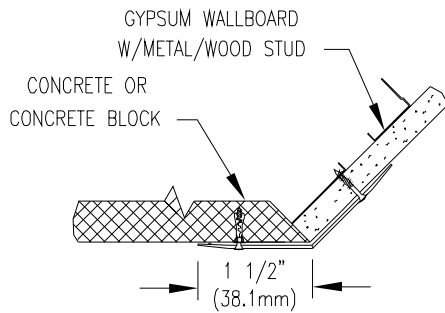

LG-150M
(135° STANDARD ANGLE U.N.O.)

ANGLES ONLY AVAILABLE BETWEEN 70° - 160°

LG-200M GUARD
AT PARTIAL HEIGHT ELEVATION

WALL CONDITION	SPECIFIED FASTENER	DRILL DIAMETERS		C/S PART NUMBER
		WALL	RETAINER	
STEEL STUD/GYPSUM WALL WOOD STUD/GYPSUM WALL CONCRETE/CONC. BLOCK	LG 034: LG 034 SCREW/NAIL	N/A	N/A	90H136002
	LG 250/200/118: LG 118/200/250 SCREW			90H135002

 Construction Specialties™ 6696 Route 405 Highway, Muncy PA 17756 (800) 233-8493 • Fax (570) 546-4692 • www.c-sgroup.com	PROJECT:		REV. :
	LOCATION:		F&F:
	CUSTOMER:		SHEET OF
	AGENT:		JOB NO.
	DWG. BY:	DATE:	