

COLOR: _____

COLOR TO BE SELECTED FROM ONE OF C/S STANDARD COLORS

QTY. REQ'D	UNIT HGT.	RET. LENGTH	COVER LENGTH	BASE HGT.	COLOR

SEND 1" TOP CAP FOR EACH UNIT REQUIRED

I) FLUSH MOUNTED CORNER GUARD SPECIFICATIONS

- 1) ACROVYN GUARDS SHALL BE MANUFACTURED FROM .078 THICK HIGH IMPACT VINYL/ACRYLIC. UNITS SHALL BE FURNISHED IN A MATTE FINISH PEBBLETTE GRAIN SURFACE IN ANY OF C/S STANDARD COLORS. CUSTOM COLORS ARE AVAILABLE UPON REQUEST, BUT SUBJECT TO QUANTITY MINIMUMS.
- 2) CONTINUOUS RETAINERS SHALL BE EXTRUDED FROM MINIMUM .063 THICK 6063-T6 ALUMINUM. EACH UNIT SHALL RECEIVE AN ETCHED FINISH TO INSURE BONDING OF FEATHER EDGE CEMENT AND APPLIED WALL FINISH.

II) FLUSH MOUNTED CORNER GUARD NOTES

- 1) ALL FULL HEIGHT UNITS TO BE FURNISHED IN LENGTHS TO ACCOMMODATE THE SPECIFIED CEILING HEIGHT, WITH 2" ADDED FOR FIELD VARIATIONS. WHERE POSSIBLE, THIS 2" SHOULD EXTEND INTO THE CEILING. PARTIAL HEIGHT OR UNITS AT SOFFIT AREAS WILL INCORPORATE A 1" ALUMINUM TOP CAP TO ALLOW THE RETAINER TO BLEND INTO ADJACENT MATERIALS. (PARTIAL HEIGHT GUARDS ARE ONLY AVAILABLE IN 1/4" NOSE RADIUS.)
- 2) A MINIMUM 24 GA CHANNEL STUDS MUST BE SECURELY ANCHORED TOP AND BOTTOM TO INSURE POSITIVE ATTACHMENT OF ALUMINUM RETAINERS. IF TRUSS STUDS ARE USED, CHANNEL STUDS MUST BE USED AT CORNER.

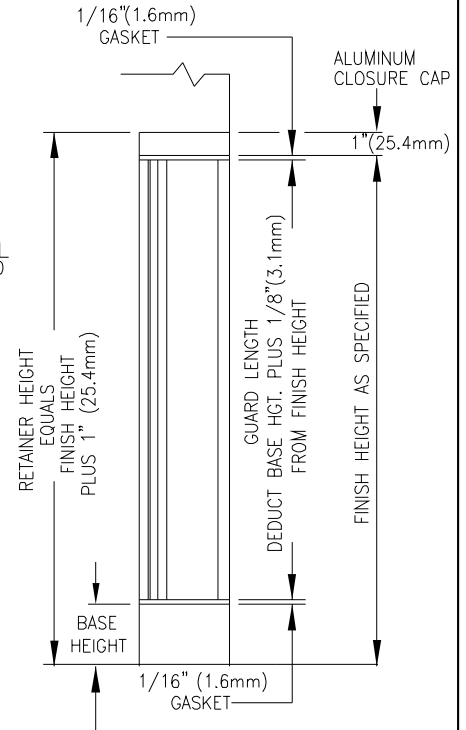
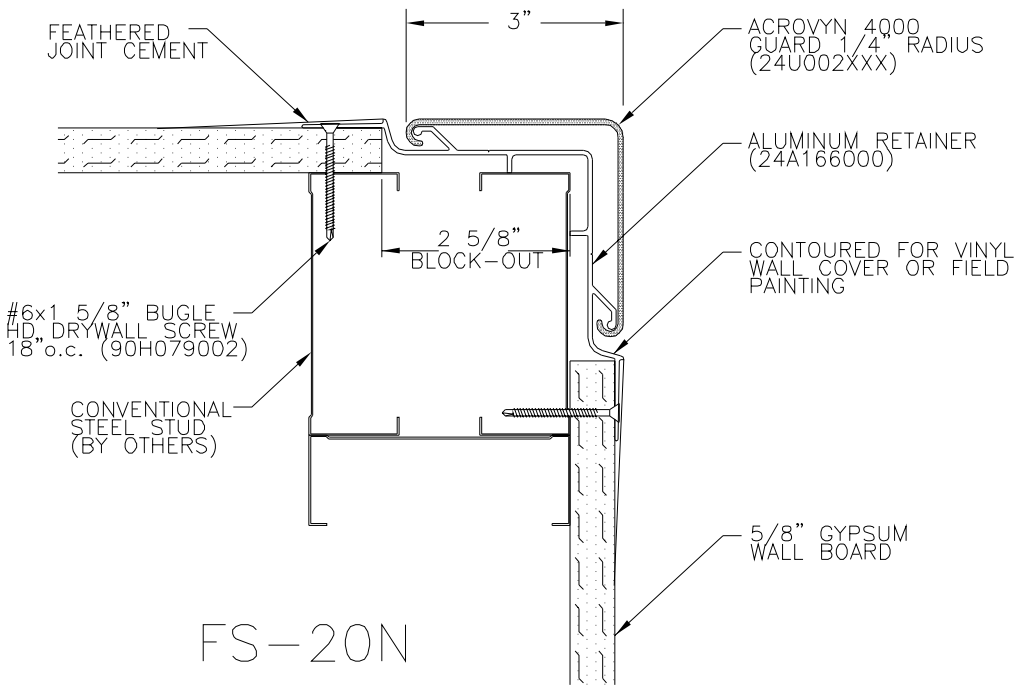
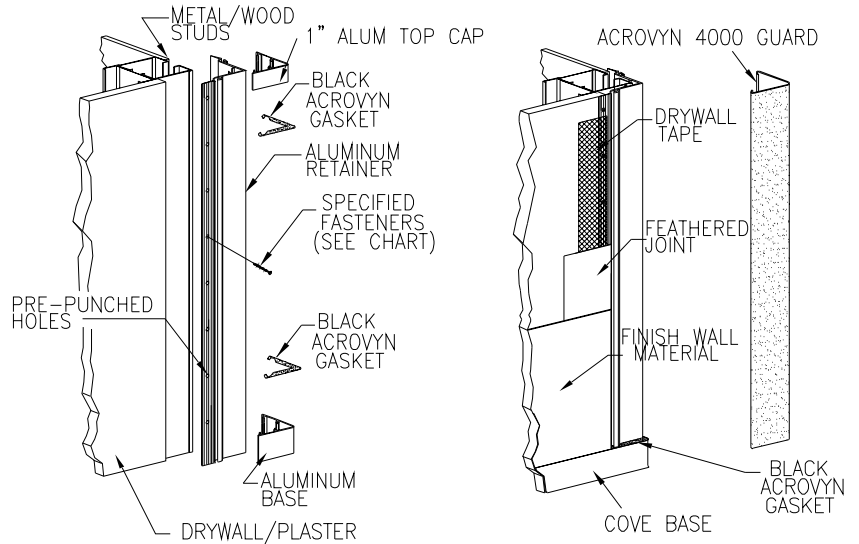

FS-20N

WALL CONDITION	SPECIFIED FASTENER	DRILL DIAMETERS		PART NUMBER
		WALL	RETAINER	
STEEL STUD/GYPSUM WALL WOOD STUD/GYPSUM WALL	#6 x 1-5/8" BUGLE HD. SMS	N/A	N/A	90H079002

FLUSH MOUNTED GUARD AT PARTIAL HEIGHT ELEVATION

 <p>Construction Specialties™ 6696 Route 405 Highway, Muncy PA 17756 (800) 233-8493 • Fax (570) 546-4692 • www.c-sgroup.com</p>	PROJECT:		REV. :
	LOCATION:		F&F:
	CUSTOMER:		SHEET OF
	AGENT:		JOB NO.
	DWG. BY:	DATE:	