

MODEL FB97-7" through 28" SEISMIC CHASE WALL FIRE BARRIER INSTALLATION INSTRUCTIONS

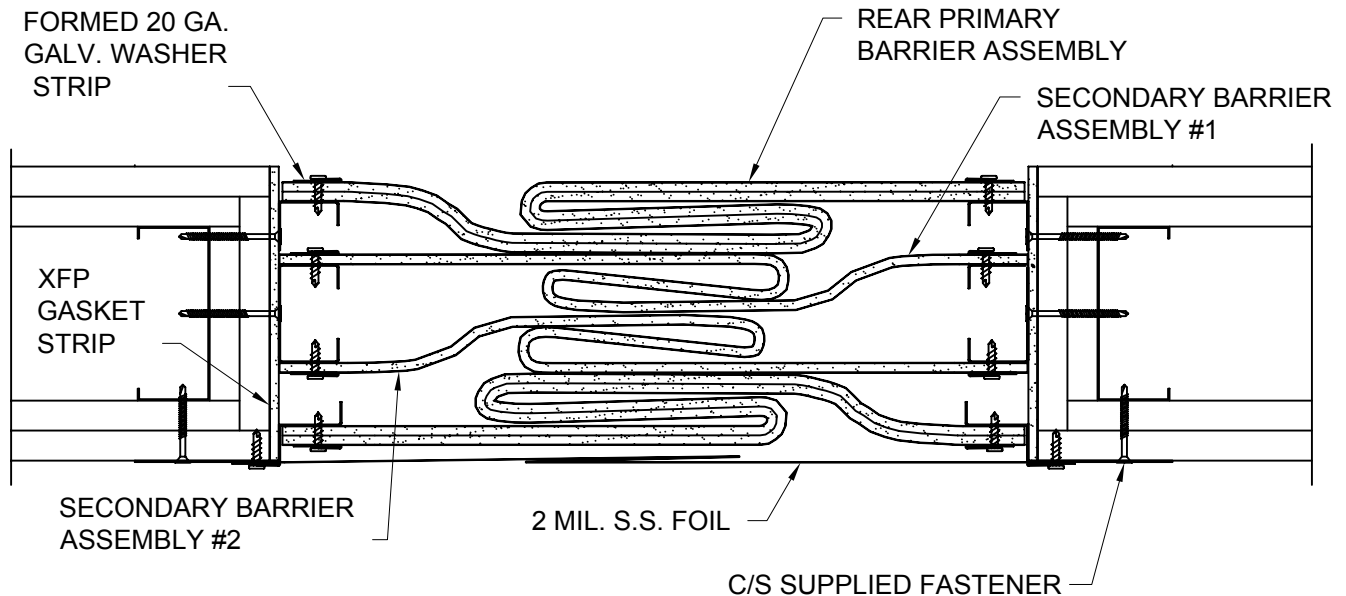

IMPORTANT INFORMATION

Prior to the commencement of Installation, all materials **MUST** be inspected for Damage. Any damage must be reported to CONSTRUCTION SPECIALTIES, INC., as soon as possible, so that replacement materials may be furnished without delay.

All work must be completed as per Architect's Approved "Shop Drawings", and in accordance with these Installation Instructions. When installation is complete, all materials must be protected from damage until the Architect's FINAL INSPECTION.

All materials should be arranged in the order that they are to be installed. All hardware required for each portion of the work should be placed with the appropriate materials.

Please review all Approved Shop Drawings and this Document to familiarize yourself with all the details and components of this assembly.

IMPORTANT:

READ THROUGH ALL INSTRUCTIONS PRIOR TO STARTING INSTALLATION

8/07

CONSTRUCTION SPECIALTIES, INC.

P.O. BOX 380
MUNCY, PA 17756
PHONE: (570)546-5941 FAX: (570)546-8022

This document is the property of Construction Specialties, Inc. and contains CONFIDENTIAL PROPRIETARY INFORMATION that is not to be disclosed to third parties and is not to be used without approval in writing from Conspec Systems, Inc.

INSTALLATION INFORMATION AND NOTES

TOOLS:

The following tools may be needed for installation of the FB-97 Wall Fire Barriers:

- Fabric or Leather Work Gloves
- Measuring Tape
- Level
- Tin Snips
- Permanent Marker
- Circular and/or Chop Saw (with both standard and abrasive blades)
- Utility Knife
- Drill
- Duct Tape
- Screwdrivers
- Staple Gun

Notes:

- 1.) ALWAYS WEAR GLOVES when handling and cutting the barrier as the edges of the stainless steel foil may cause cuts.
- 2.) Before beginning installation, review the architectural drawings and the approved Conspec shop drawings to establish which rated walls are to receive fire barrier.
- 3.) Check the joint to make sure that it is clear of any materials that will impede installation of the fire barriers. Make sure that the area around the joint is clean and accessible.

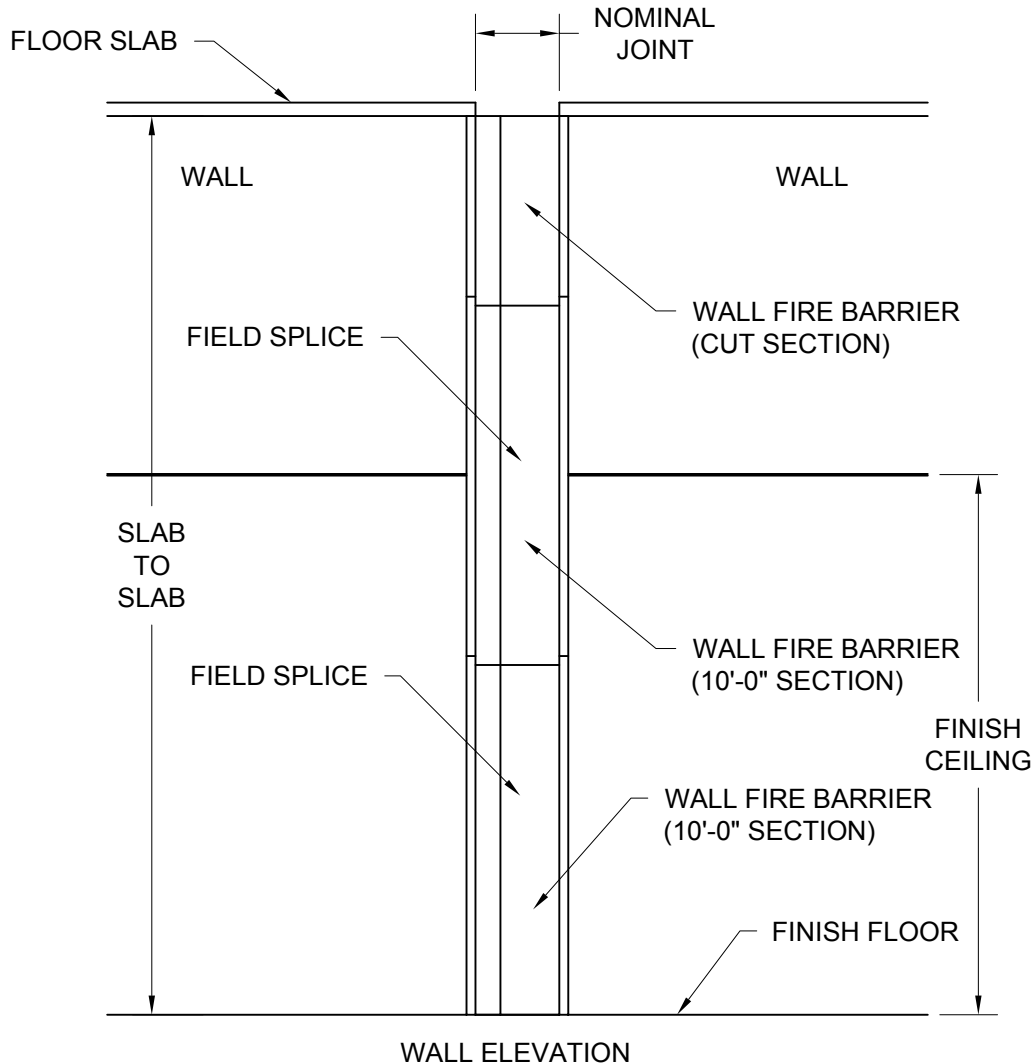

Installation Notes:

- 1.) Wall Fire Barriers are to extend the full height of the rated wall, from floor slab to the underside of the floor slab above.
- 2.) The Wall Fire Barrier Assemblies have been supplied in 5'-0" and 10'-0" lengths and are to be field spliced together to cover the overall height. Each Assembly has been supplied with offset layers for field splicing.
- 3.) Each section of Wall Fire Barrier incorporates (4) Assemblies, (2) Primary Barrier Assemblies and (2) Secondary Barrier Assemblies.
- 4.) All of the Wall Fire Barrier Assemblies shipped have been marked with a "Mark Number" which corresponds with the Mark Numbers indicated on the approved Construction Specialties shop drawings. These Mark Numbers indicate the barrier's location in the building. Before beginning installation, all of the Assemblies for a given Mark Number should be gathered at that location.
- 5.) Field cutting Barriers to the specific overall length may be required.

Notes:

Before beginning installation, review the Architectural Drawings and approved Construction Specialties Inc. shop drawings to familiarize yourself with the joint cover models and locations.

Check all of the joint cover components to confirm that the correct joint cover model and size have been received. Also, check for materials that may have been damaged during shipping. Report all incorrect and/or damaged components to C/S at 800-233-8493.

Read through all the steps of these instructions prior to beginning work.

STEP 1

INSTALLING XFP GASKET STRIPS

CHASE AREA (NO ACCESS)

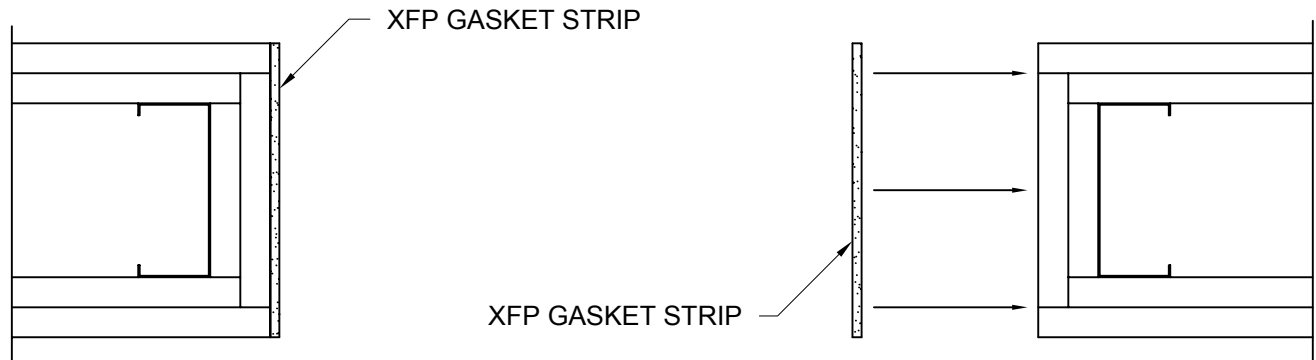

INTERIOR

STEP 1:

Note: The XFP Gasket Strip may or may not have been supplied with a peel and stick backing. If not, use a staple gun to anchor the strip in place for installation.

- 1.1) Cut a section of Gasket Strip long enough to reach from the floor to the slab above. (Note: You may also splice sections of Gasket Strip together to accommodate the full height. Simply butt the ends tightly together when installing.)
- 1.2) Beginning at the top of the wall, align one vertical edge of the Gasket Strip with one face of the wall, begin to peel the backing, and press the Pressure Sensitive Adhesive to the inside wall of the joint.
- 1.3) Maintain alignment with the joint edge and continue to peel and stick the Gasket Strip as you work towards the floor.
- 1.4) Repeat for the opposite joint face.

TYPICAL FIRE BARRIER FORMING INSTRUCTIONS

Note: Secondary barrier shown - primary barrier folded the same configuration.

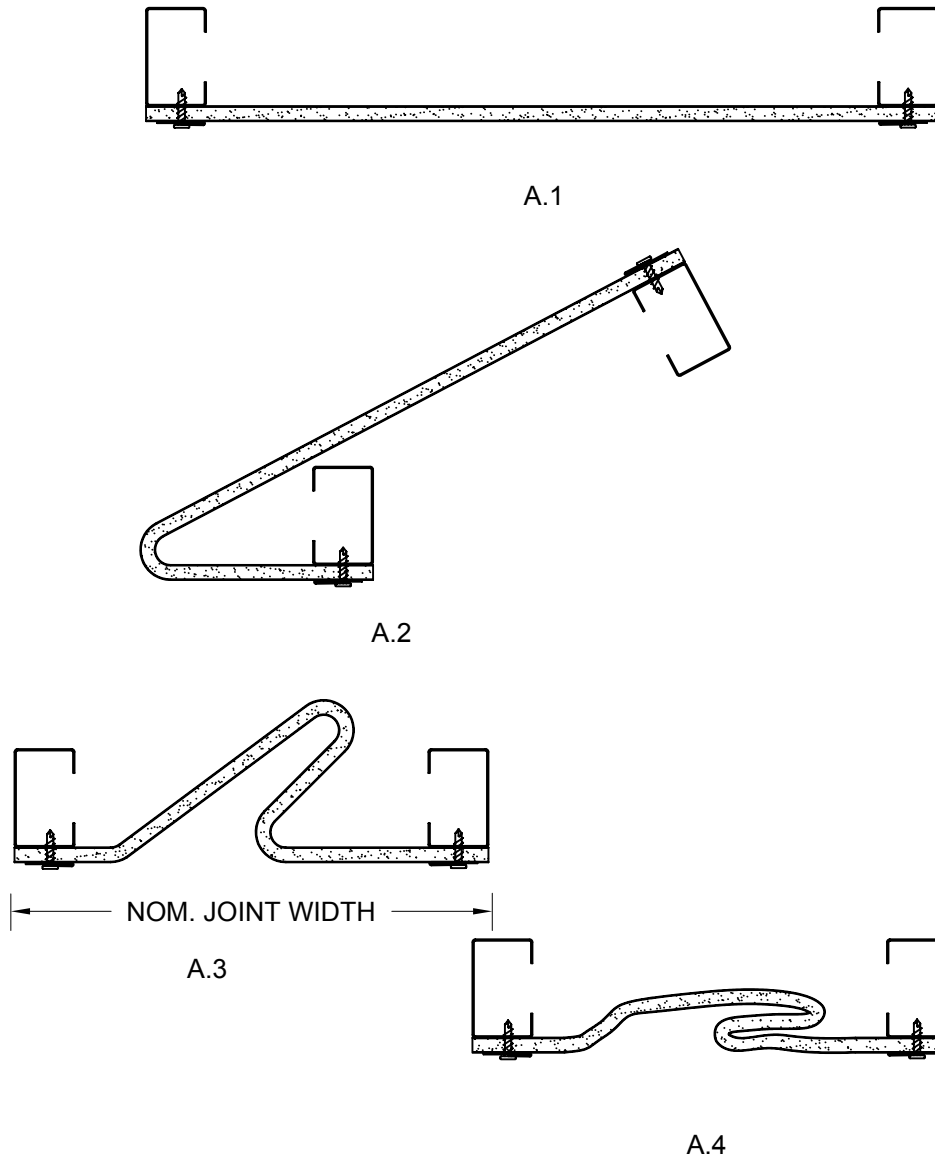

Note: All of the Fire Barrier Assemblies have been shipped flat and must be formed to the profiles indicated to accommodate the nominal joint opening. Follow these basic forming instructions for each assembly.

- A.1) Place the Barrier Assembly face down, flat on the floor.
- A.2) At approximately $\frac{1}{3}$ of the overall width in from one edge, fold the opposite edge of the Barrier back.
- A.3) From just inside the outer edge (or inside the Galvanized Retainer), fold the long leg back so that the outside edges of the Barrier are at the nominal joint width.
- A.4) While maintaining the edges at the nominal joint width, press down along the folded edges to form them to the profile. (Note: Use Duct Tape to hold the Barrier in this profile while handling for installation.)

STEP 2

REAR PRIMARY BARRIER INSTALLATION

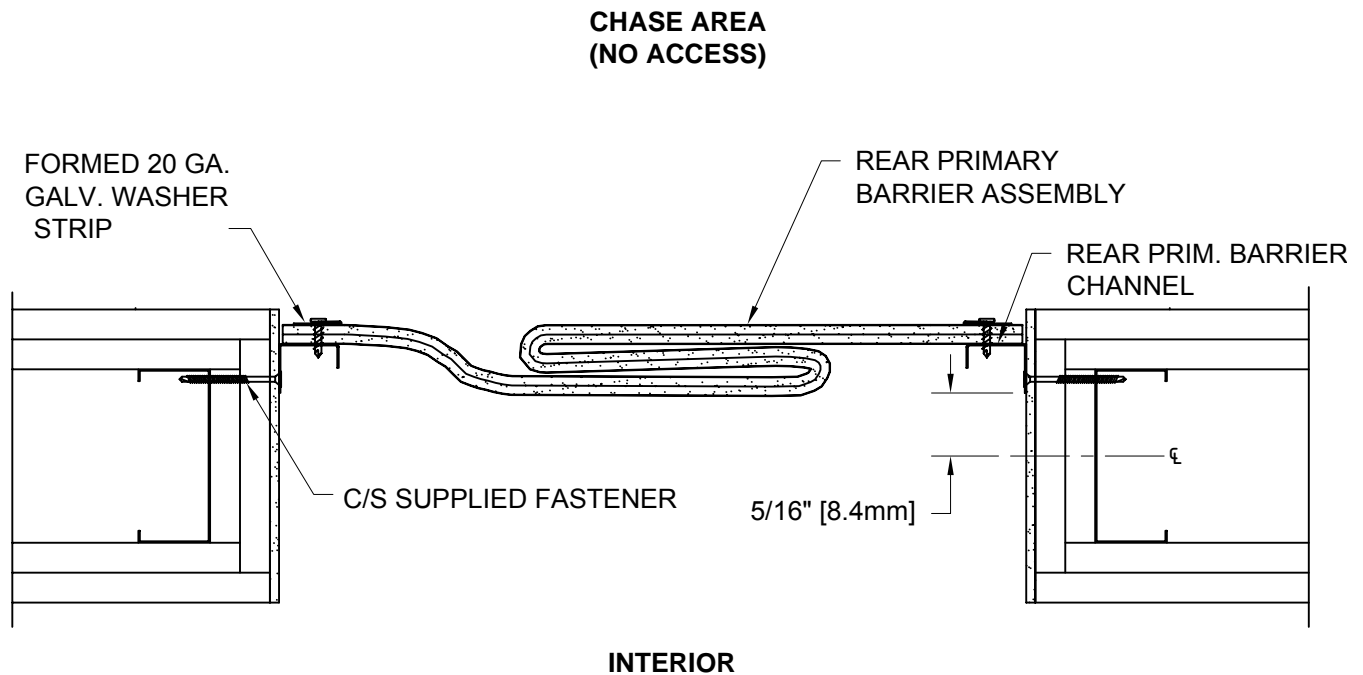

STEP 2:

- 2.1) Locate the center of the wall thickness and mark with a marker, measure back from the center of the wall face $\frac{5}{16}$ " to locate the edge of the Rear Primary Barrier Channel.
- 2.2) With the section of Rear Primary Barrier Assembly folded as shown, install with the flanges oriented as shown in the detail above aligning the edge of the Galvanized Channel with the previously located mark. Using the Construction Specialties supplied fasteners, secure the retainer to the inside of the joint edge. Repeat for all locations and the opposite side of the Galvanized Channel.
- 2.3) Determine the length for the next barrier section by measuring from the top of the Galvanized Retainer to the bottom of the slab above. If greater than 10'-0", proceed to Step 3 for Splicing Primary Barrier. If less than 10'-0", mark and cut the Assembly to the required length. (Note: Cut from the appropriate end to maintain splicing offset.)
- 2.4) Form the Barrier section to profile as instructed, assuring that the folds are made in the same direction as the previous section.
- 2.5) Apply a heavy bead of Firestop Sealant to the offset layer of the bottom section of Barrier. Position the next section so that the fold fits together and the splice layers overlap. (See splice details on next page.)
- 2.6) Butt the Galvanized Retainer end to end as indicated and anchor in position with the Construction Specialties supplied fasteners.
- 2.7) Repeat steps 2.1 - 2.6 as required to install to full height.

STEP 3

PRIMARY BARRIER SPLICING ELEVATION

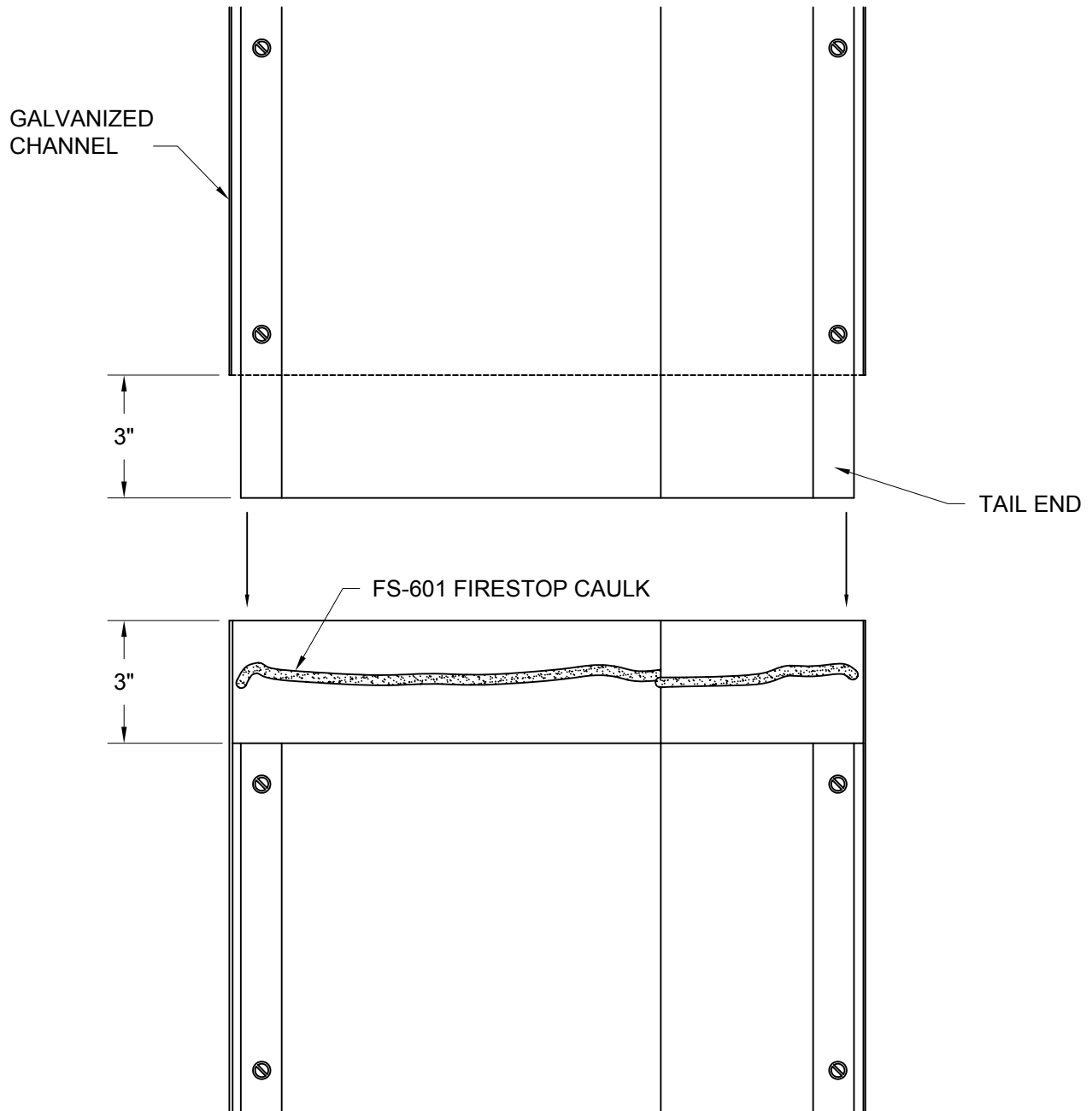

STEP 4

INSTALLING SECONDARY BARRIER ASSEMBLY #1

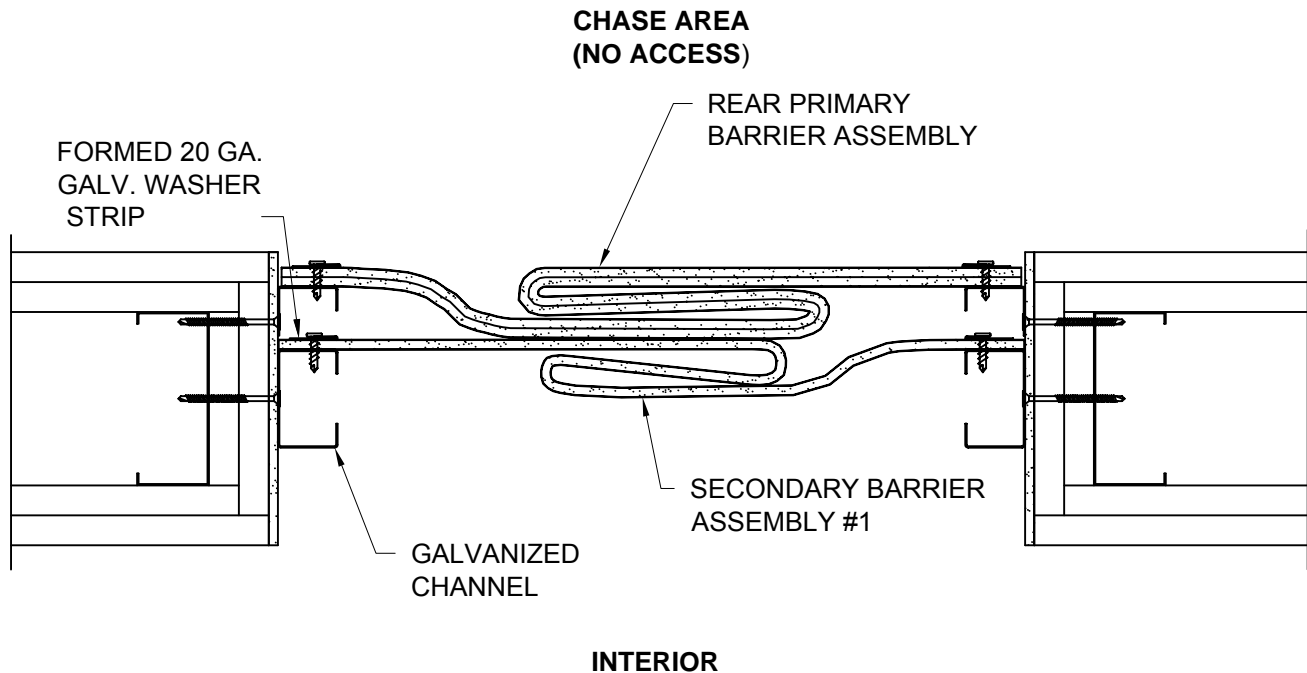

STEP 4:

Note: Each section of Secondary Barrier Assembly #1 has been supplied with a 6" offset at each end for field splicing. Begin installation at the bottom of the wall. The end of the barrier with the Galvanized Channels extending should be at the top. Install all Secondary Barrier Assemblies for the full height before proceeding to the next step.

- 4.1) Having formed the Bottom Barrier Assembly to profile as instructed, begin at the bottom of the joint and position one of the Galvanized Channels of the Barrier Assembly between the vertical lines and anchor with the appropriate Construction Specialties supplied fasteners.
- 4.2) Repeat for the opposite Galvanized Channel.
- 4.3) Establish the length for the next Barrier Assembly by measuring from the top of the Galvanized Channel of the Bottom Assembly to the underside of the slab above. If greater than 10'-0", proceed to step 5. If less than 10'-0", measure the next Assembly from the bottom end of the Galvanized Channel (the end with the 6" splice extension), mark and cut the Assembly to the required length.
- 4.4) Form the Barrier section to profile as instructed, assuring that the folds are made in the same direction as the previous section.

SEE PAGE 9 TO COMPLETE INSTALLATION.

STEP 5

SECONDARY FIRE BARRIER SPLICE ELEVATION

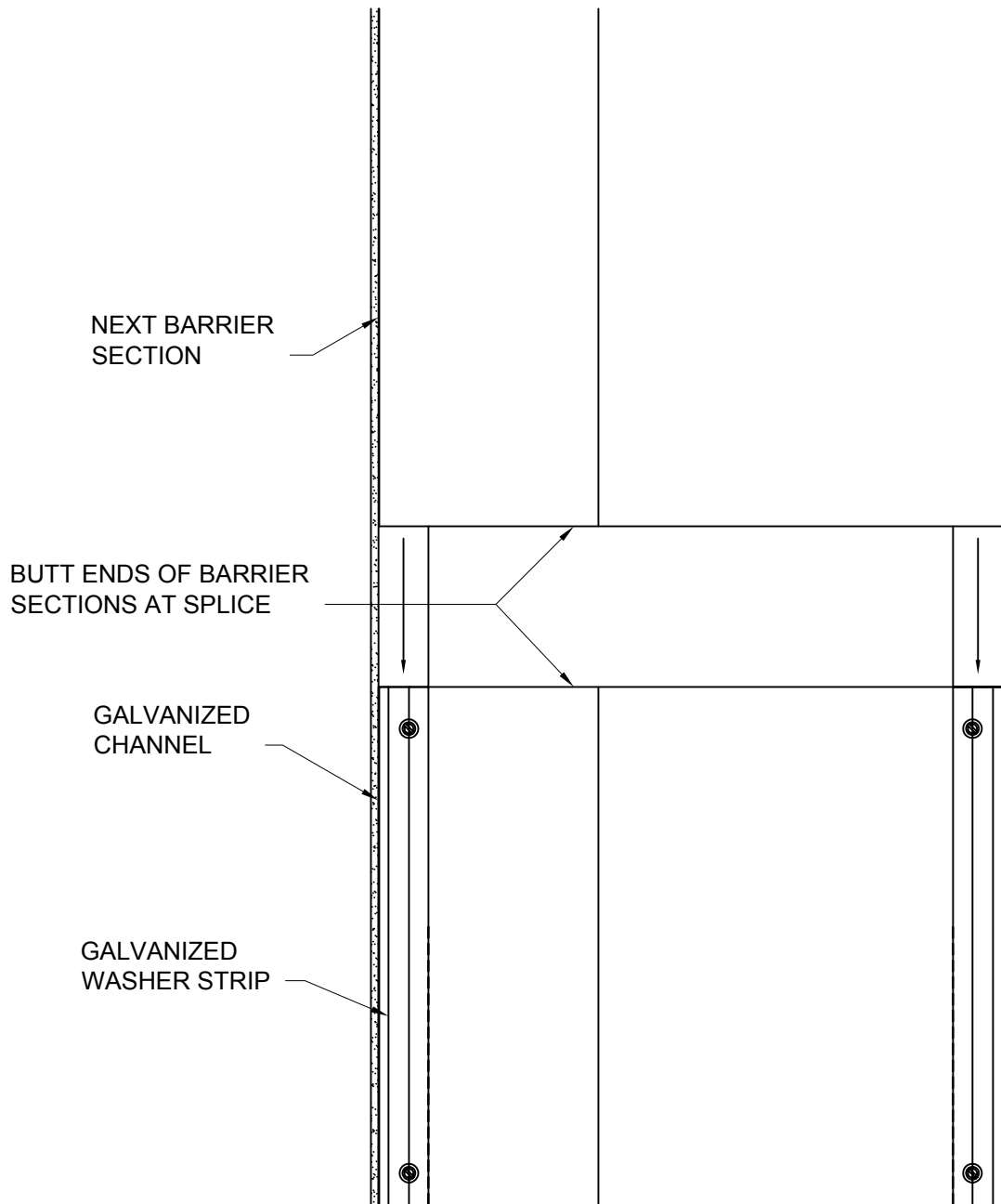

STEP 5:

- 5.1) Fit the barrier on top of the previous section while matching the folds. The ends of the barriers should butt together as the splice end overlaps the channels of the first section to form the splice.
- 5.2) Align the channels with the plumb lines and anchor the section with the appropriate fasteners.
- 5.3) Repeat steps 4.1 thru 5.2 as needed to complete installation to full height.

STEP 6

INSTALLING SECONDARY BARRIER ASSEMBLY #2

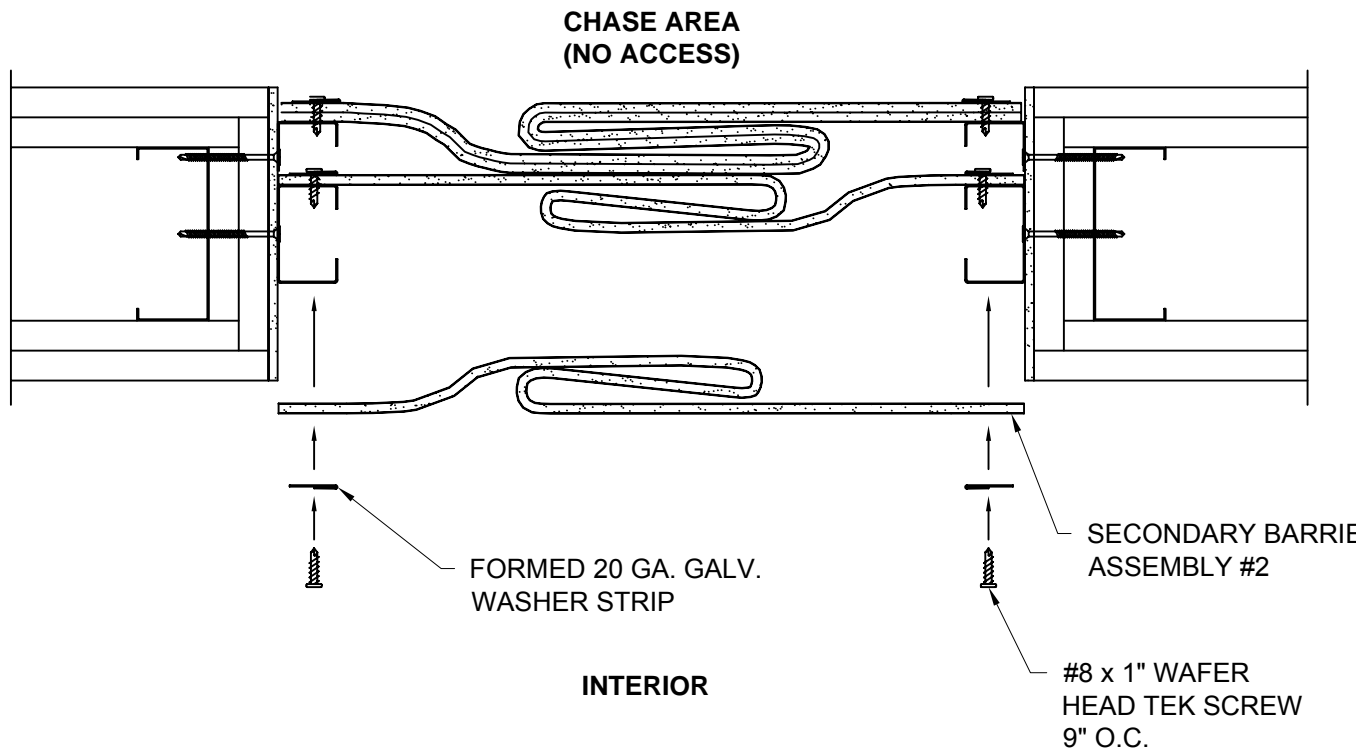

STEP 6:

Note: In order to offset the splice joints, the Secondary Barrier #2 is to be installed from the top down. There is no specific bottom assembly with Secondary Barrier Assembly #2.

- 6.1) Form a section of Barrier to profile as instructed, begin at the underside of the slab and position one edge of the Barrier against the XFP Gasket Strip and seat it against the Galvanized Channel. (Note: It may be helpful to tape the top end of the Barrier section to the Galvanized Channel to hold it in place for attachment.)
- 6.2) Using the Galvanized Washer Strip and #8 x 1" Wafer Hd. TEK Screws as provided, anchor the Barrier to the Galvanized Channel.
- 6.3) Repeat for the opposite edge of the Barrier.
- 6.4) Measuring from the bottom of the installed Barrier to the finished floor, determine the length of the bottom section. If greater than 10'-0", proceed to step 6.5. If less than 10'-0", cut a section of Secondary Barrier #2 to the required length.
- 6.5) Form the barrier section to profile as instructed, assuring that the folds are made in the same direction as the previous section. Follow Step 5 for splicing Secondary Barrier Assemblies together.
- 6.6) Repeat steps 6.2 - 6.5 as needed to complete the installation to the floor.

STEP 7

INSTALLING INTERIOR PRIMARY BARRIERS

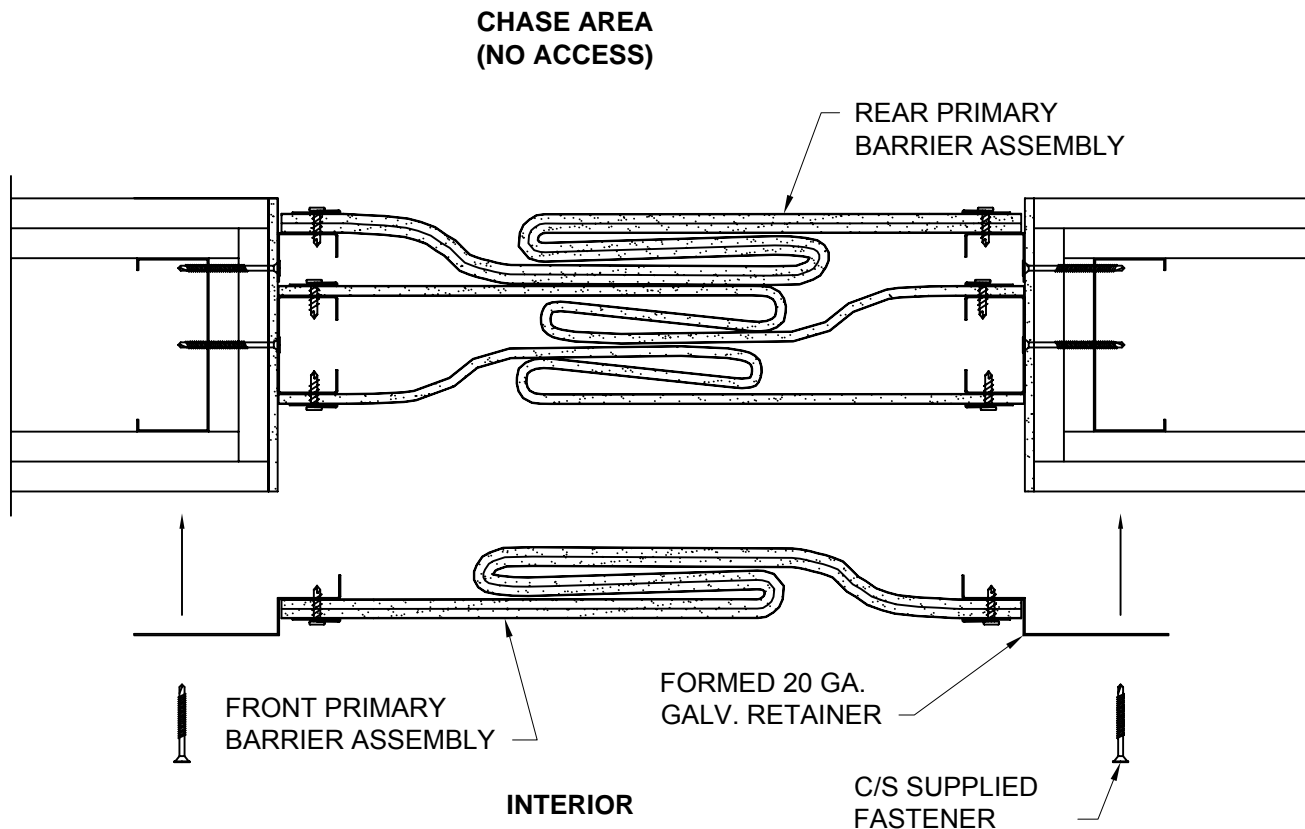

STEP 7:

Note: The Stainless Steel Foil face of the Primary Barrier Assembly is to face outward. Each Primary Barrier Assembly has the layers offset 3" at the ends to allow for field splicing.

- 7.1) Form a section of Primary Barrier to profile as instructed, begin at the bottom of the joint and position one of the Galvanized Retainers of the Barrier over the corner of the wall and XFP Gasket Strip.
- 7.2) While holding the Galvanized Retainer tightly to the Gasket Strip, anchor the Retainer with the appropriate C/S supplied fasteners.
- 7.3) Repeat for the opposite Retainer.
- 7.4) Determine the length for the next Barrier section by measuring from the top of the Galvanized Retainer to the bottom of the slab above. If greater than 10'-0", proceed to step 7.5. If less than 10'-0", measure, mark and cut the assembly to the required length. (Note: Cut from the appropriate end to maintain splicing offset.)
- 7.5) Form the barrier section to profile as instructed, assuring that the folds are made in the same direction as the previous section.
- 7.6) Apply a heavy bead of Firestop sealant to the offset layer of the bottom section of Barrier. Position the next section so that the folds fit together and the splice layers overlap. (See splice details on page 12.)
- 7.7) Butt the Galvanized Retainers end to end as indicated and anchor in position with the appropriate fasteners.
- 7.8) Repeat steps 7.4-7.7 as required to complete installation to full height.

STEP 7 (CONT.)

PRIMARY BARRIER SPLICING DETAIL

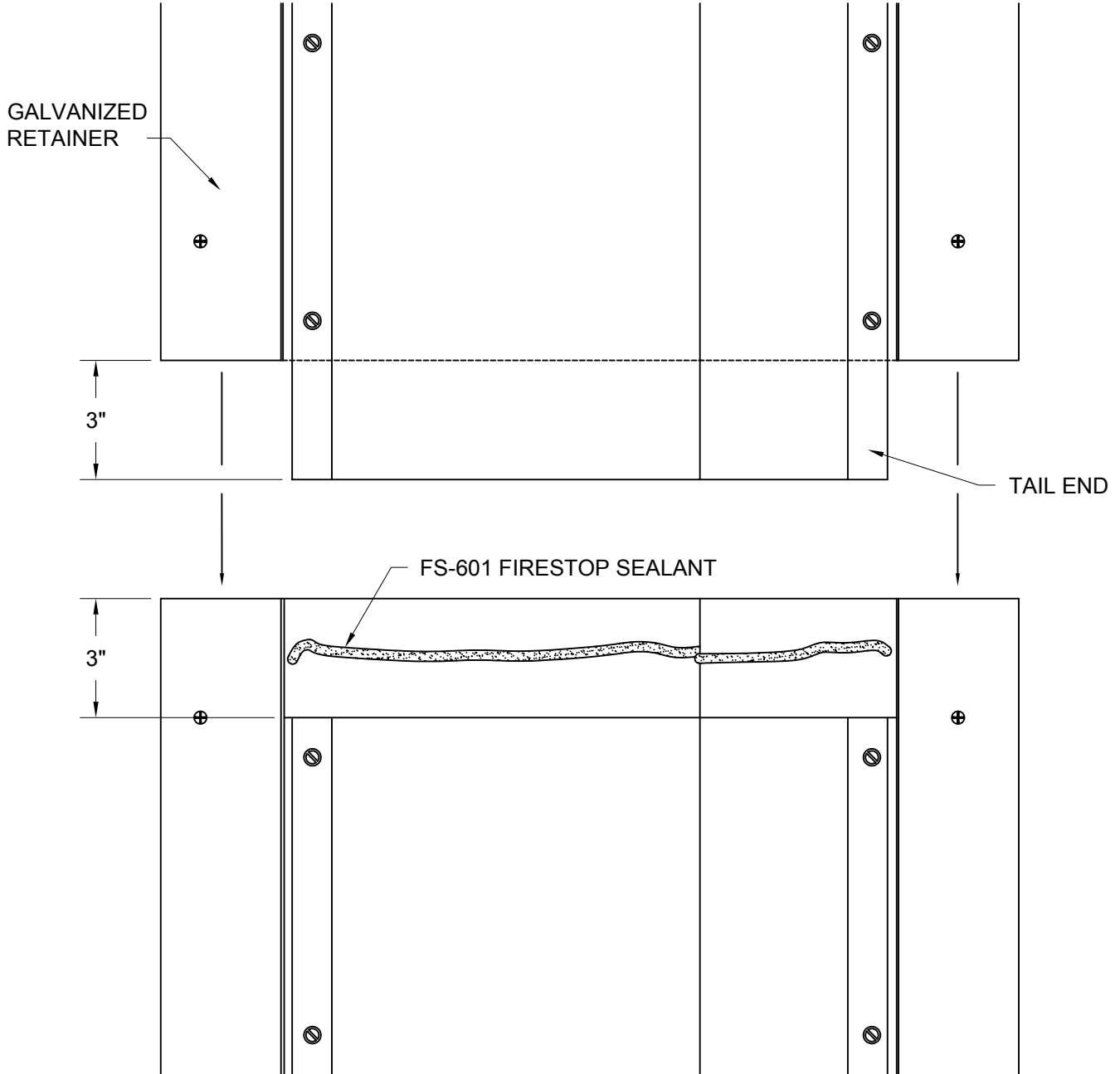

STEP 8

2 MIL S/S FOIL COVER SHEET INSTALLATION (AS REQUIRED)

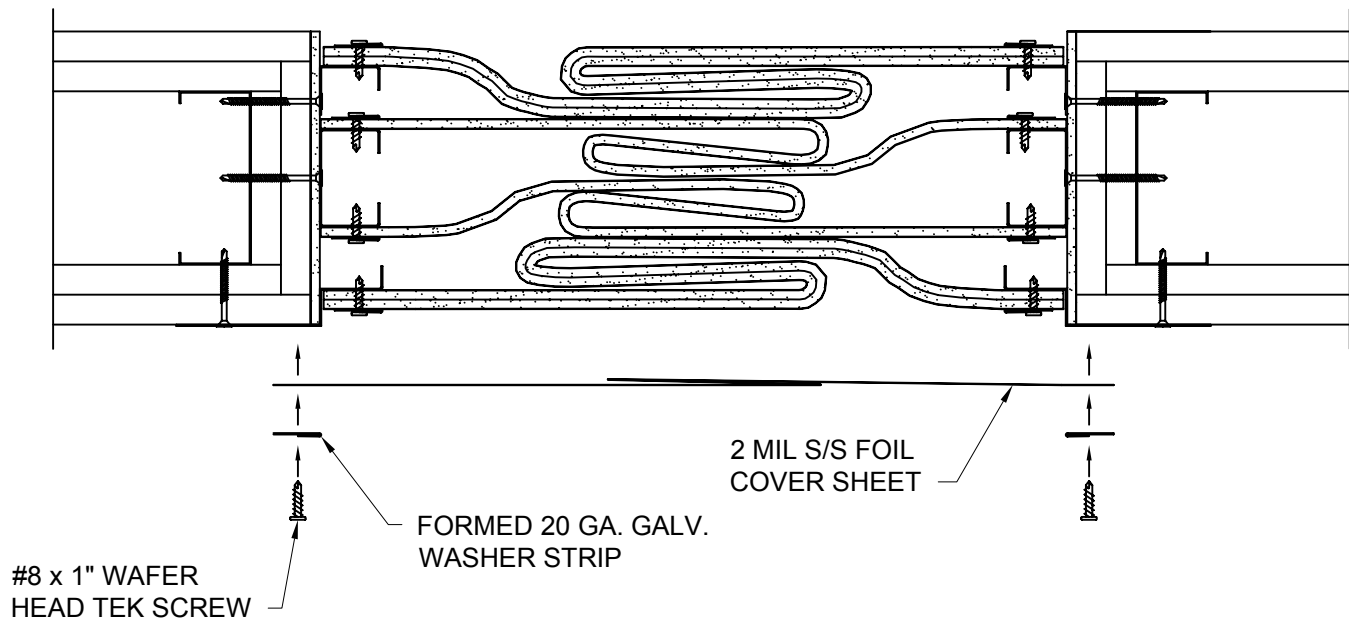

STEP 8:

Note: S/S Foil Cover only required where indicated on approved C/S shop drawings. When required, begin installation at the top of the wall in order to offset splices. It will be helpful to tape the section of Foil in place with Duct Tape while fastening.

- 8.1) Fold a section of the S/S Foil Cover to profile as indicated.
- 8.2) Position the Foil Cover over the opening so that the edges overlap the Galvanized Retainers 1" onto the face of the wall.
- 8.3) Using the Galvanized Washer Strips and #8 x 1" Wafer Head TEK Screws as provided, anchor the Foil to the Galvanized Retainer as shown.
- 8.4) Repeat for the opposite edge of the Foil Cover.
- 8.5) Measure from the bottom of the Foil Cover to the finished floor. If greater than 10'-0", proceed to step 8.6. If less than 10'-0", add 6" to the measurement for the overlap splice, mark the Foil Cover and cut it to length.
- 8.6) Fold the Foil to the profile as indicated, assuring that the folds are made in the same direction as the previous piece.
- 8.7) Position the Foil as indicated above and so that it overlaps the previous sheet of Foil by 6".
- 8.8) Measure and cut the Galvanized Washer Strips to the appropriate length. Anchor the Foil with the Washer Strips and screws as described above.
- 8.9) Repeat steps 8.5 - 8.8 to complete the installation of the Foil Cover to the finished floor.