

1"-3" FLOOR, REFLEX FIRE BARRIER INSTALLATION INSTRUCTIONS

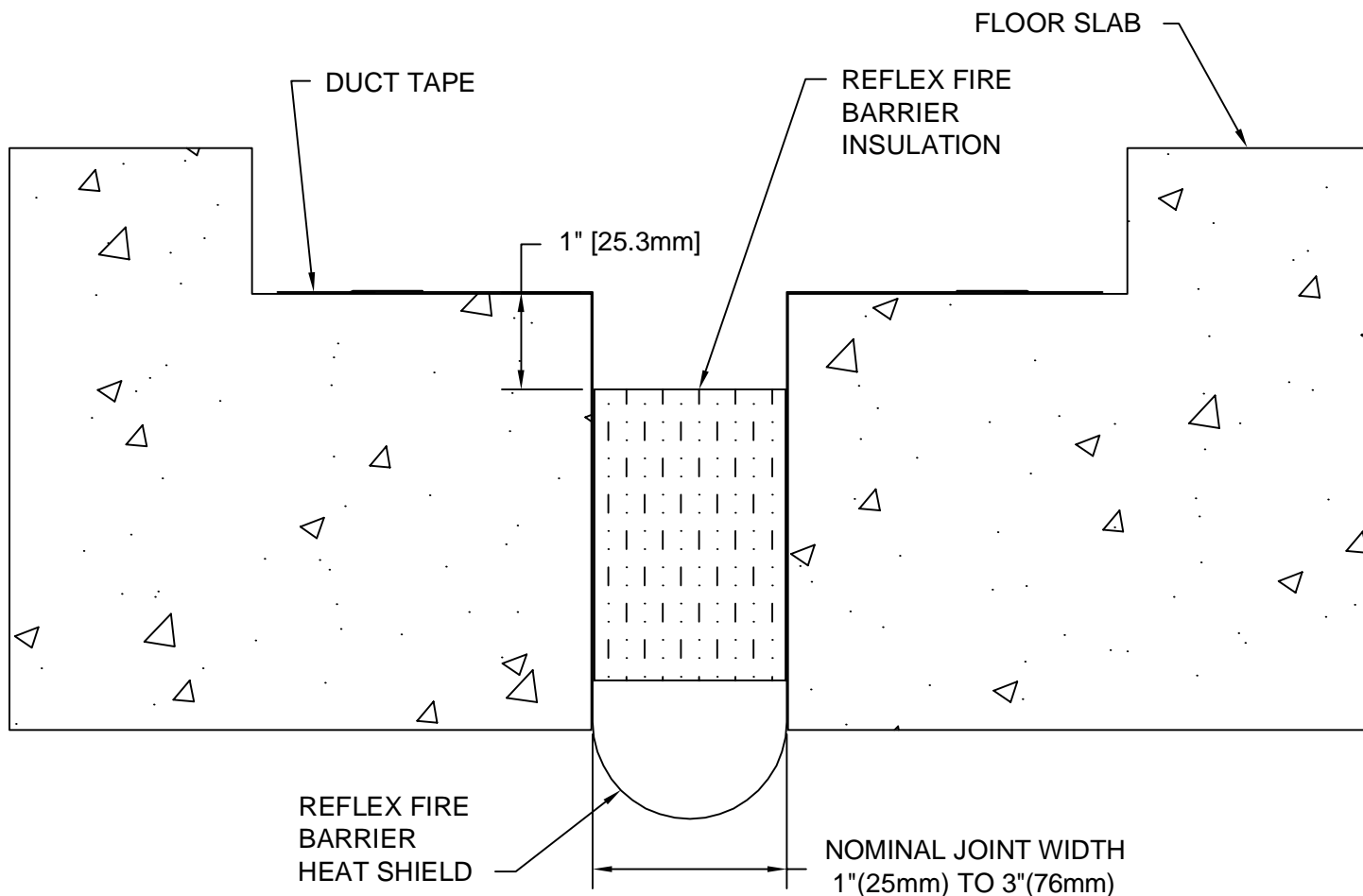

IMPORTANT INFORMATION

Prior to the commencement of Installation all materials **MUST** be inspected for Damage. Any damage must be reported to CONSTRUCTION SPECIALTIES, INC., as soon as possible, so that replacement materials may be furnished without delay.

All work must be completed as per Architect's Approved "Shop Drawings," and in accordance with these Installation Instructions. When installation is complete, all materials must be protected from damage until the Architect's FINAL INSPECTION.

All materials should be arranged in the order that they are to be installed. All hardware required for each portion of the work should be placed with the appropriate materials.

Please review all Approved Shop Drawings and this Document to familiarize yourself with all the details and components of this assembly.

IMPORTANT:

READ THROUGH ALL INSTRUCTIONS PRIOR TO STARTING INSTALLATION

6/21/11

CONSTRUCTION SPECIALTIES, INC.

P.O. BOX 380
MUNCY, PA 17756
PHONE: (570)546-5941 FAX: (570)546-8022

This document is the property of Construction Specialties, Inc. and contains CONFIDENTIAL PROPRIETARY INFORMATION that is not to be disclosed to third parties and is not to be used without approval in writing from Construction Specialties, Inc.

GENERAL NOTES

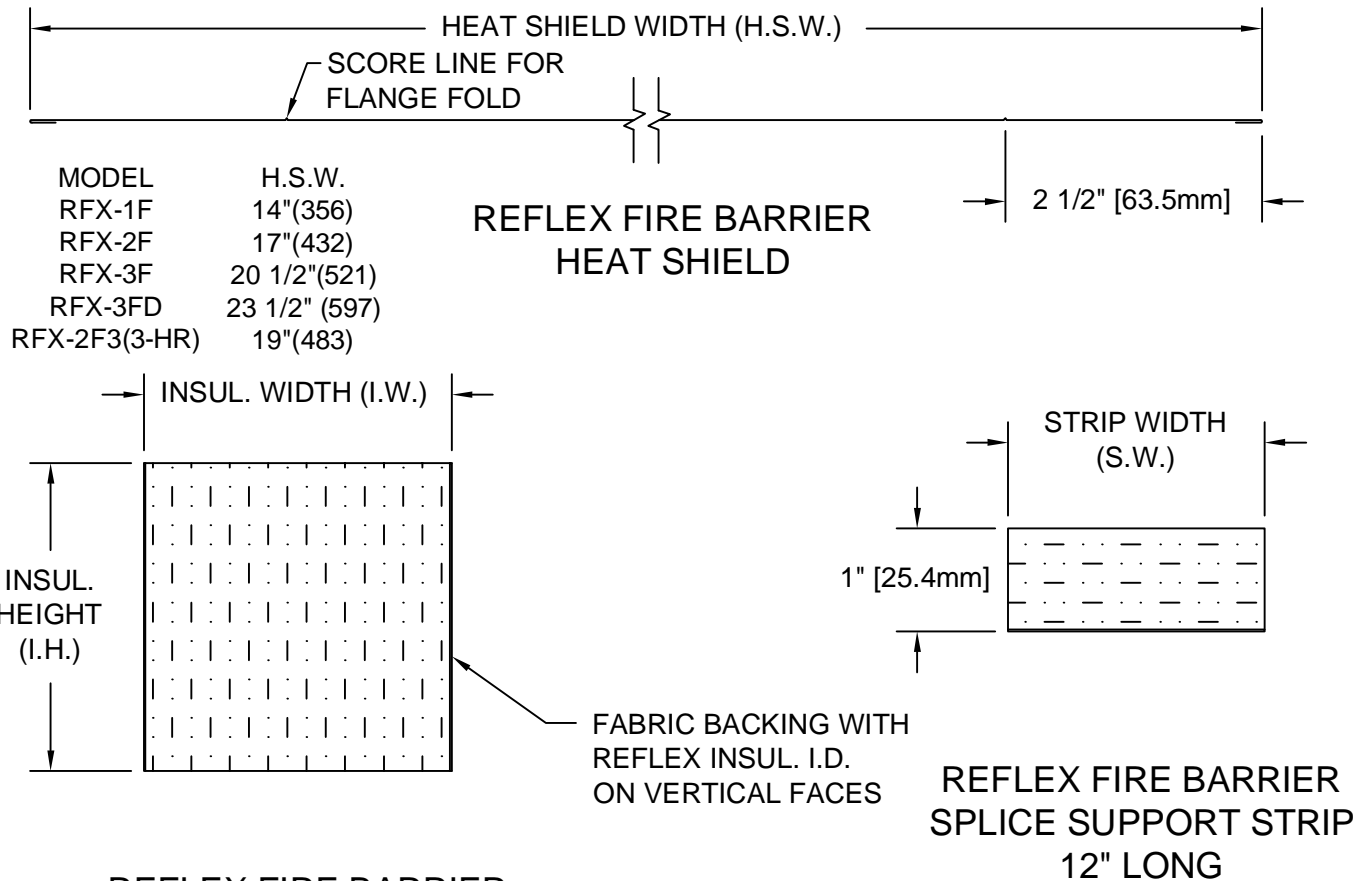

MODEL	H.S.W.
RFX-1F	14"(356)
RFX-2F	17"(432)
RFX-3F	20 1/2"(521)
RFX-3FD	23 1/2" (597)
RFX-2F3(3-HR)	19"(483)

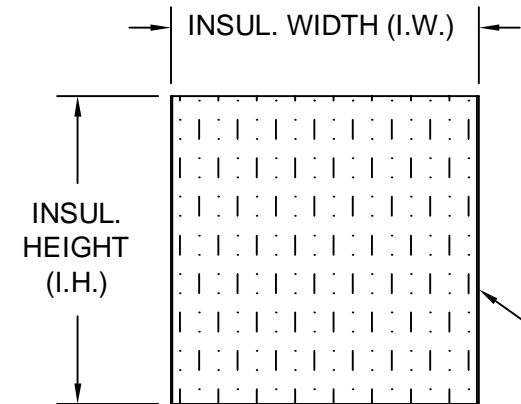

REFLEX FIRE BARRIER INSULATION

MODEL	I.W.	I.H.
RFX-1F	2"(51)	2 1/2"(64)
RFX-2F	4"(102)	3"(76)
RFX-3F & RFX-3FD	6"(152)	4"(102)
RFX-2F3(3-HR)	4"(102)	4"(102)

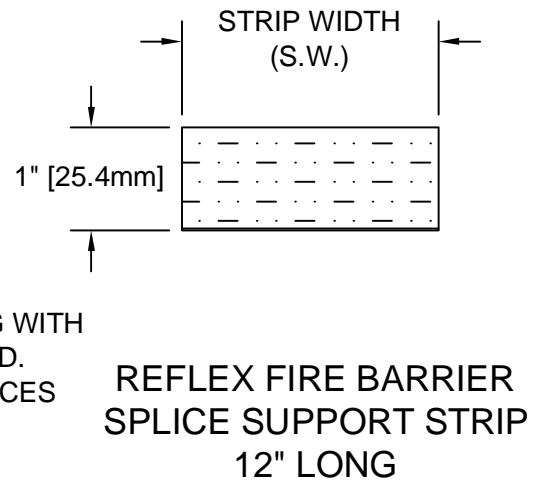

REFLEX FIRE BARRIER SPLICE SUPPORT STRIP 12" LONG

MODEL	S.W.
RFX-1F	1 1/2"(38)
RFX-2F	2 1/2"(64)
RFX-3F & RFX-3FD	4"(102)
RFX-2F3(3-HR)	2 1/2"(64)

1.) The Reflex Fire Barriers are typically installed in conjunction with a Construction Specialties, Inc. expansion joint cover system. These instructions assume that the floor slabs and blockouts have been prepared as required for the specific expansion joint cover system. Please review the architectural drawings, approved Construction Specialties, Inc. shop drawings and specific expansion joint cover installation instructions to determine the specific requirements for slab preparation.

2.) Before beginning installation and cutting any length of barrier, review the architectural drawings and the approved shop drawings to establish the extent of the run of fire barrier. Special consideration must be given to the following conditions:

- At each end of a run of barrier, the barrier should extend beyond the finished face of the walls to the end of the slabs (or as indicated by the architect). Establish this dimension and add material to the length of barrier as required.
- The floor fire barrier must extend beyond the finished face of walls where the barrier is required to transition to vertical wall fire barriers. In most cases, the floor fire barrier will simply continue along the run. However, in isolated areas where the floor fire barrier is to stop, extend the floor barrier a minimum of 9"(227mm) beyond the face of the wall to allow material for the transition.
- When the length of a run exceeds the length of the available barrier, the barriers must be spliced together. See field splicing information within these instructions.

3.) There are three basic components for the Reflex Fire Barriers: Heat Shield, Reflex Insulation and Splice Support Strips. Confirm that the components received are the appropriate sizes for the project, based on the sizes indicated above.

ALWAYS WEAR GLOVES AND DUST MASK when handling and cutting the barrier components and review all M.S.D. sheets before proceeding.

STEP 1

BEGIN HEAT SHIELD INSTALLATION

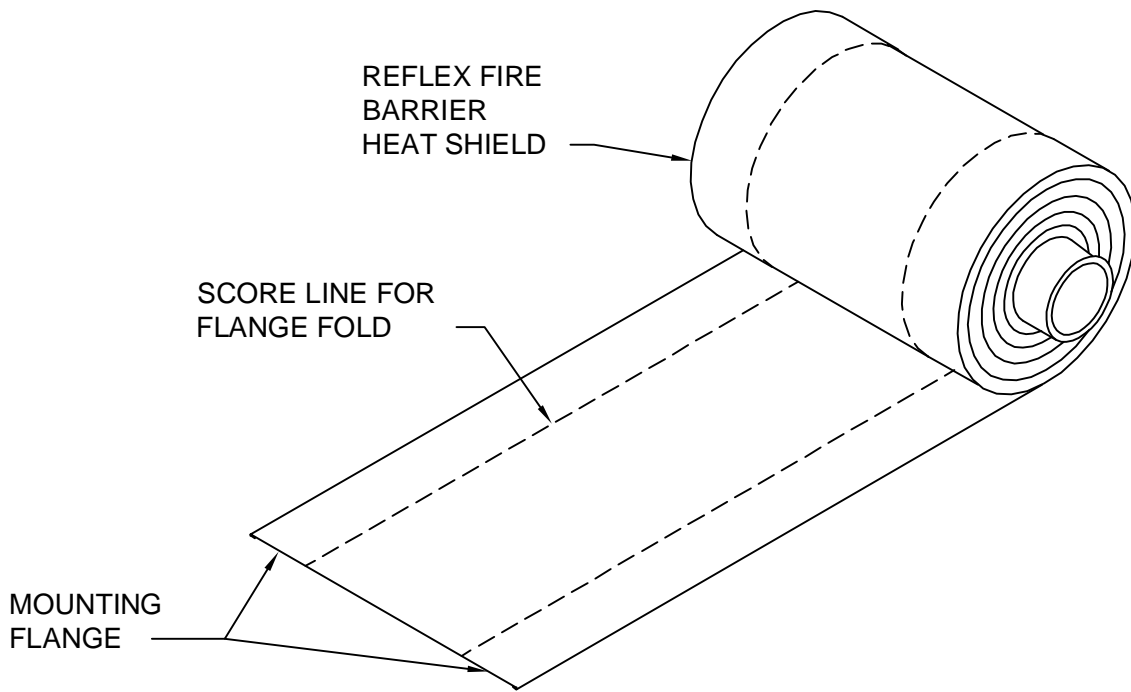

Note: The Reflex Fire Barrier Heat Shields are supplied in coiled rolls, at a standard 50'(15.2M) length.

1.1) Determine the length of Heat Shield required for the first run of fire barrier. Note: Add length as needed to address end conditions and/or transitions. If the run length exceeds the Heat Shield length, a field splice will be required. See Heat Shield Field Splice instructions, Step 2. Add 6"(152mm) of material for a field splice, 3"(76mm) at the end of each piece.

1.2) Roll out a length of Heat Shield parallel to the joint.

1.3) Measure and mark the face of the Heat Shield for the appropriate length.

1.4) Cut the Heat Shield to the required length using scissors, tin snips or a utility knife and straight edge.

STEP 2

HEAT SHIELD FIELD SPLICE

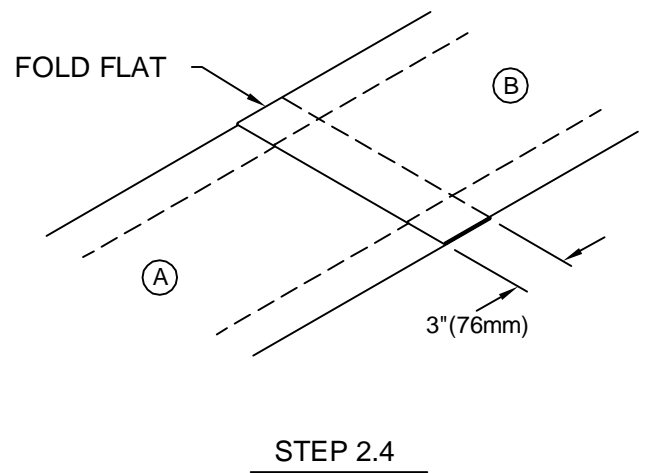
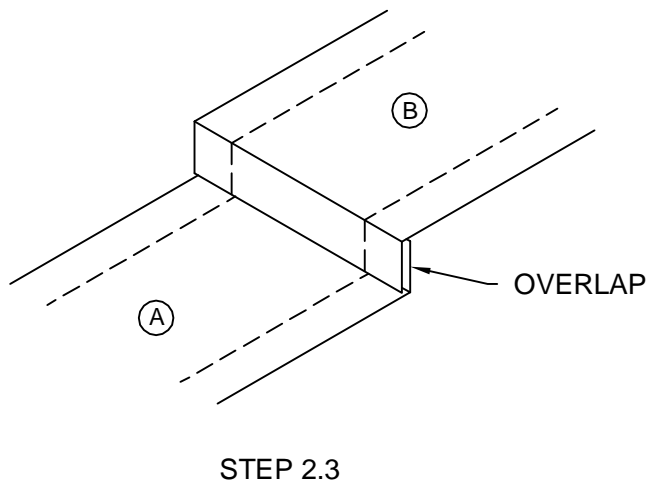
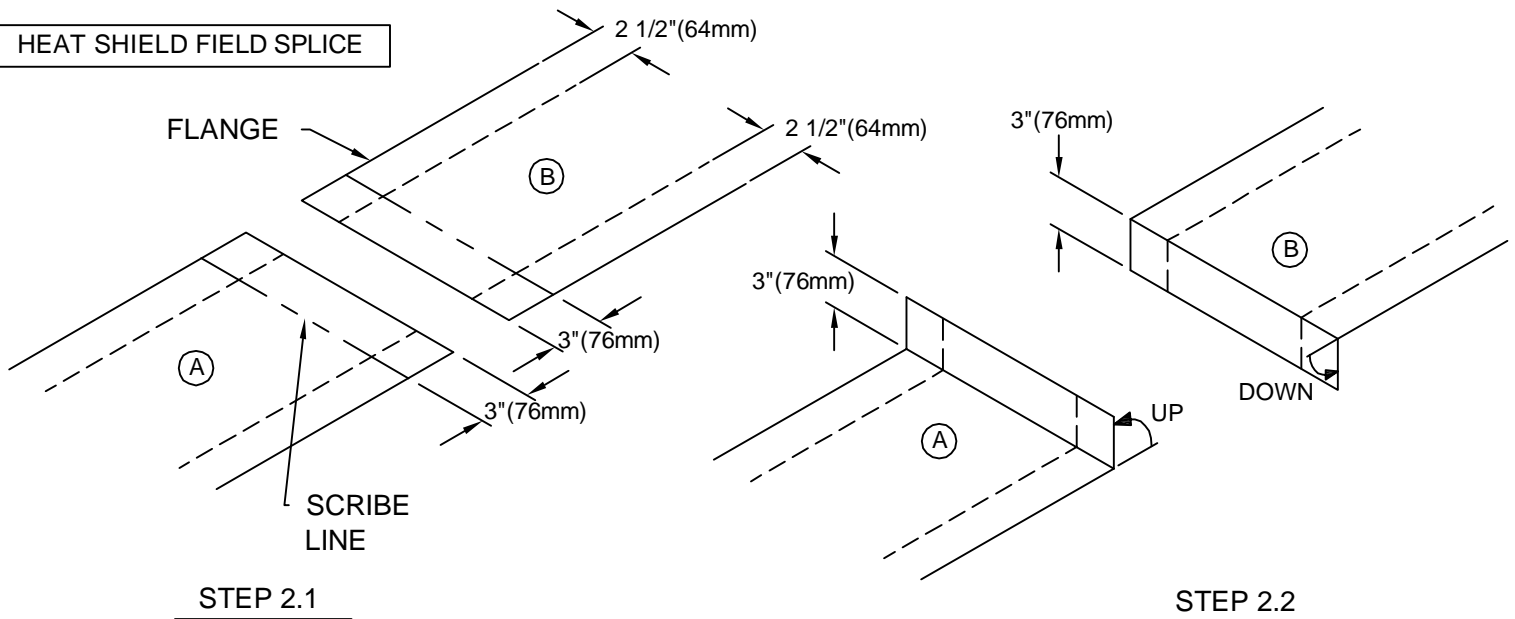

Note: When longer lengths of Heat Shield are required, lengths may be spliced together as instructed. To create a Field Splice the two lengths of Heat shield must be 9" longer than the joint length. It may be best to leave extra and trim to the run length after the splice is created.

- 2.1) Position the ends of the two lengths of Heat Shield to be spliced near each other. Measure in 3" (76mm) from the end and scribe a folding line on the surface of each piece.
- 2.2) Using a straight edge as a guide, fold the end of length "A" up at 90° and the end of length "B" down at 90°.
- 2.3) Place piece "B" over piece "A" so the folded, 3" (76mm) lengths overlap.
- 2.4) Fold the overlapping 3" (76mm) legs of both pieces flat so that they interlock to form an overlapping splice.

STEP 3

INSTALL HEAT SHIELD

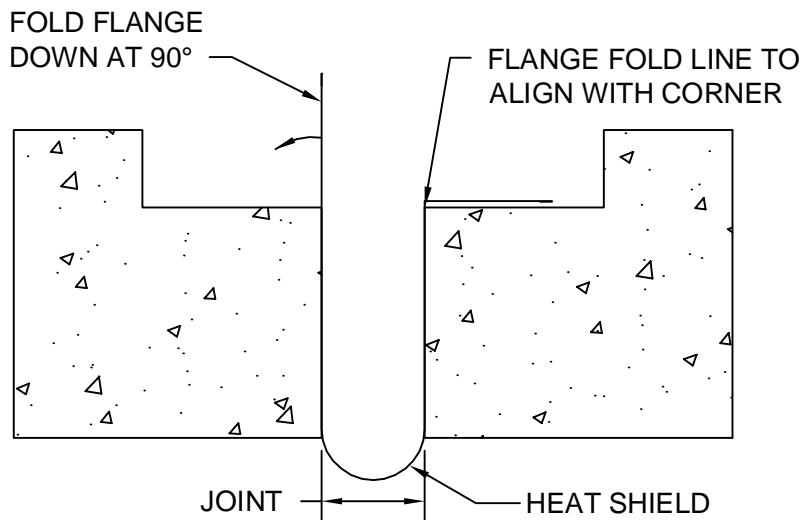
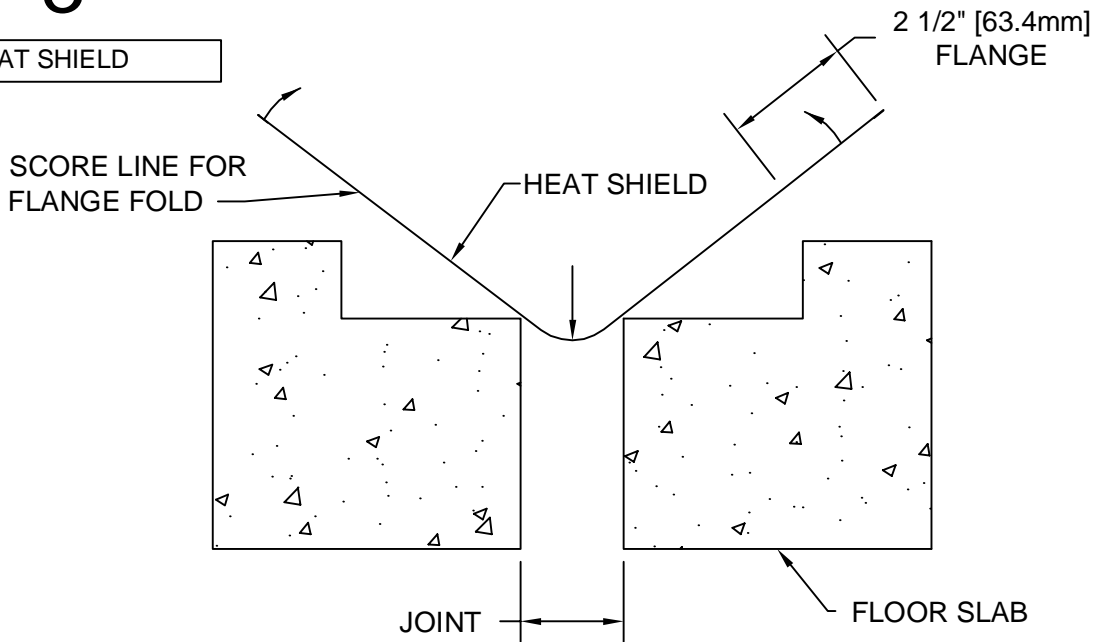

Note: With the Heat Shield for a given run cut to the appropriate length and spliced when necessary, the Heat Shield is ready to install.

- 3.1) Position the full length of Heat Shield so that it is centered over the joint.
- 3.2) Push down at the center of the Heat Shield while lifting at the flanges. The Heat Shield will start to slide down into the joint and form to a "U" shape. **Note:** Avoid creasing the Heat Shield across the width of the material. If a crease develops, remove the Heat Shield from the joint and smooth out the crease.
- 3.3) Continue to lower the Heat Shield into the joint until the flange fold lines are aligned with the corner of the slabs.
- 3.4) Fold each mounting flange down at 90° so the flanges rest on the top surface of the slabs.

Continued next page.

STEP 3 (Cont.)

INSTALL HEAT SHIELD

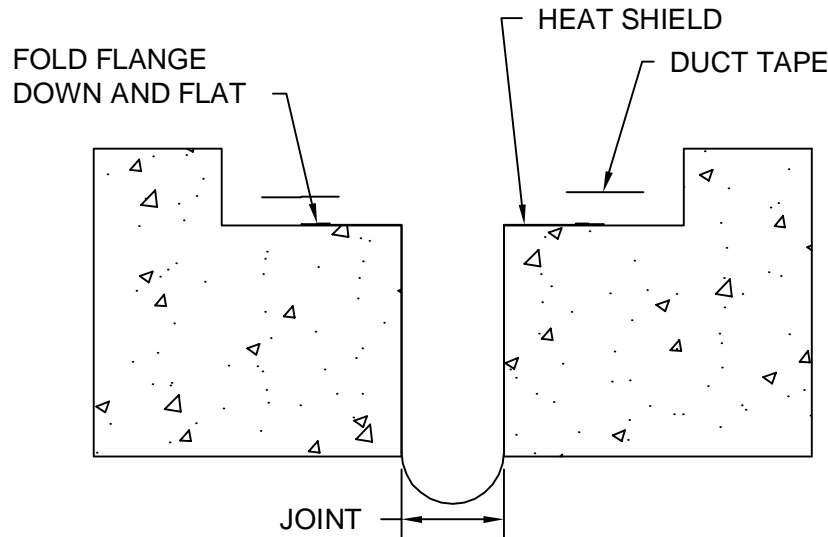
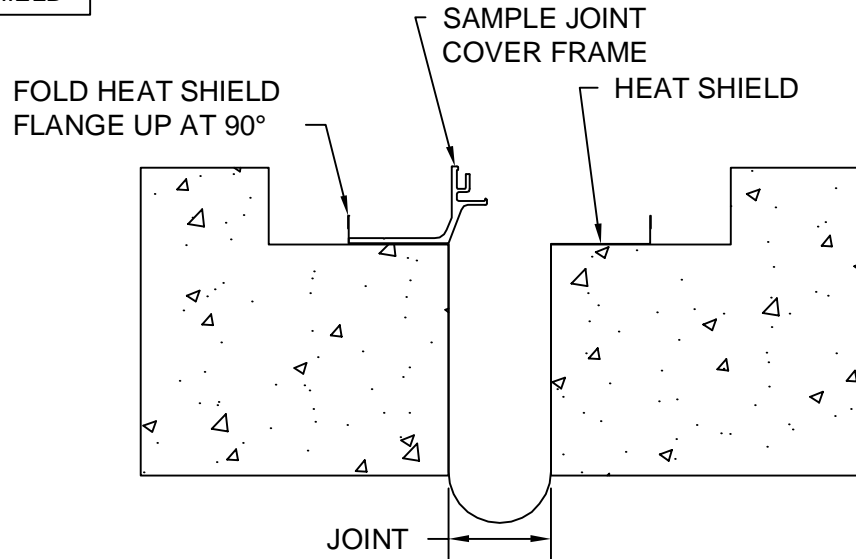

Note: The standard Heat Shield Flange width is 2 1/2" (64mm). The flange should not extend beyond the width of the Joint Cover Frame as it may prevent the backfill grout from bonding to the slab blockout. If the flange width is greater than the Joint Cover Frame width, the flange width must be shortened as instructed below.

3.5) Place a length of the appropriate Joint Cover Frame on top of the Heat Shield Flange with the inside edge of the Frame aligned with the edge of the joint.

3.6) Fold the Heat Shield Flange up along the back edge of the Frame.

3.7) Remove the Frame and fold the flange down and flat over the entire length.

3.8) Place 6" (152mm) to 9" (227mm) strips of duct tape along the edge of the flanges and tape the flange to the slabs. The tape strips should be placed every 18" (457mm) to 24" (610mm). Note: The tape is used to prevent the Heat Shield from slipping further into the joint and will hold the Heat Shield in position until mechanically anchored under the Frames of the appropriate joint cover system.

Note: Excess Heat Shield Flange width may be cut off and removed if preferred.

STEP 4

HEAT SHIELD TRANSITION

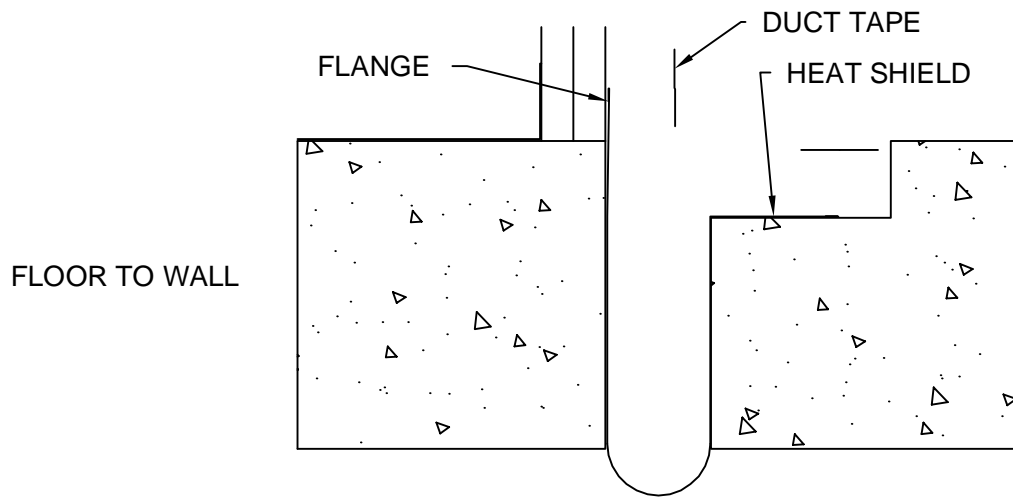
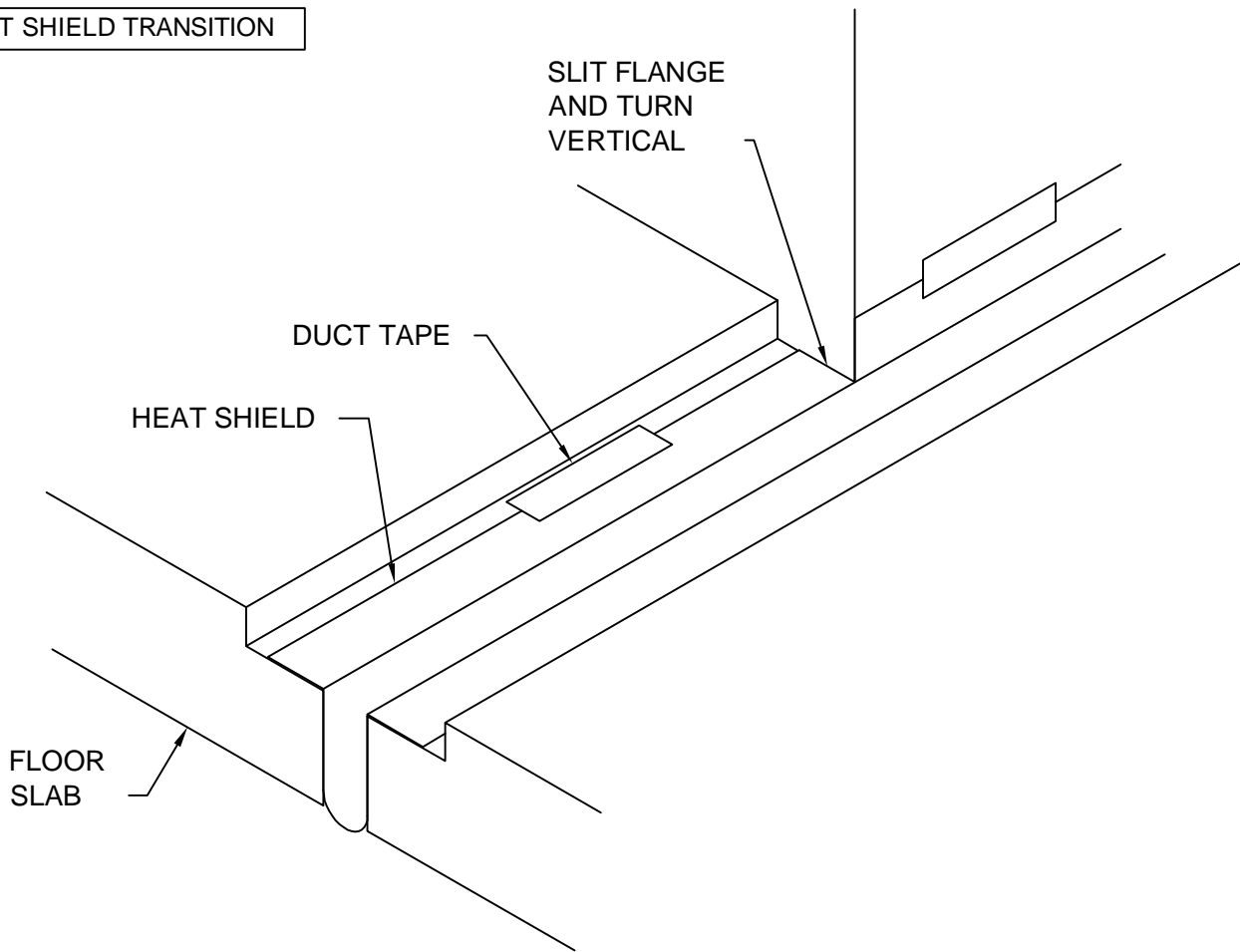

Note: When the application changes from floor-to-floor to floor-to-wall, and when the Heat Shield passes through walls or columns, the Heat Shield flange must be cut to create a transition as instructed below.

4.1) Position the Heat Shield into the joint as instructed in Step 3.

4.2) At each location where the Flange on the slab meets a vertical surface, slit the Flange inward from the outside edge, approx. 2 1/2"(64mm).

4.3) Fold the Flange up at 90° so that it will rest against the vertical face. Note: Fold over or remove excess Flange width as indicated in Step 3.

4.4) Tape the Flange to the face of the wall.

STEP 4 cont.

90° HEAT SHIELD TRANSITION

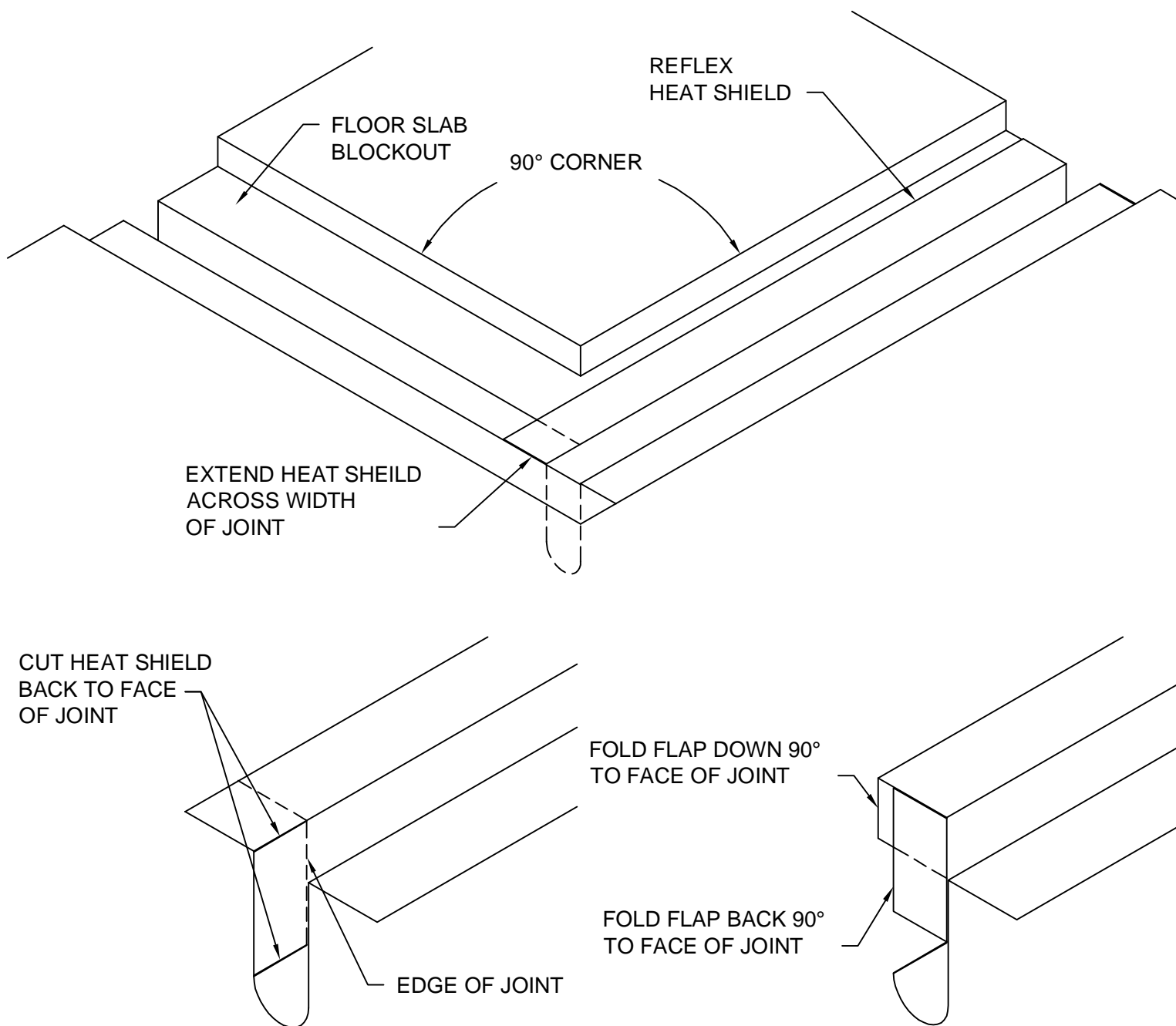

4.5) Position the Heat Shield into the joint as instructed in Step 3.

4.6) At each corner, extend the Heat Shield to the face of the joint on the opposite side.

4.7) Cut the heat shield back to the face of the joint as shown above. Fold the section of heat shield back to the face of the joint.

4.8) Tape these section back to hold until fire barrier has been installed. .

STEP 5

PREPARING INSULATION FOR INSTALLATION

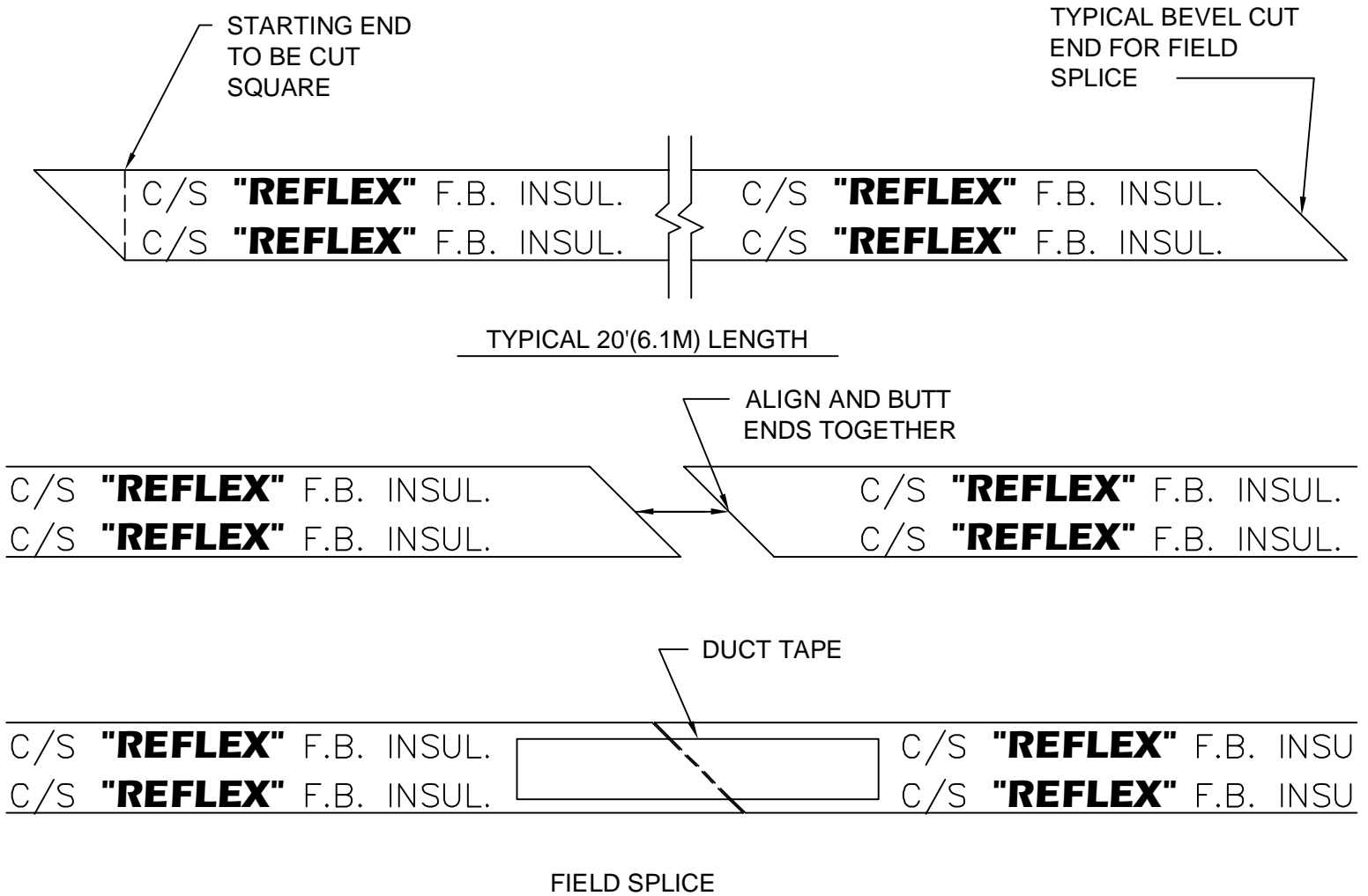

Note: With the Heat Shield in place, the Reflex Insulation must be prepared for installation. The Insulation is to run the full length of the installed Heat Shield. The Insulation is provided in stock 20'(6.1M) lengths with a bevel cut at each end. Where necessary, field splice lengths together to provide enough insulation length for the entire run. The Insulation is most easily cut with a household, serrated edge, bread knife with a blade approx. 10" in length.

5.1) The end of each run is to be cut square. If starting with a stock length, position the Insulation along side the joint and orient the Insulation as shown with the printed fabric on the vertical faces and end bevel up. Square cut the end.

5.2) If the length of the run is to be less than a stock 20' length, measure, mark and cut the Insulation to the appropriate length.

5.3) If additional length is required, position the next length of insulation so that the opposite bevel cuts align. Bring the ends of the Insulation block together, align the vertical faces, and place a 12"(304mm) length of duct tape across the butt joint. Press the tape onto the surface of the Insulation to assure a good bond. Note: The tape will help to keep the ends of the insulation tightly together and in alignment during installation.

5.4) Continue to splice together as many lengths as needed for the given run. The final length should be cut to the required length and the end is to be cut square.

STEP 6

INSTALL SPLICE SUPPORT STRIPS

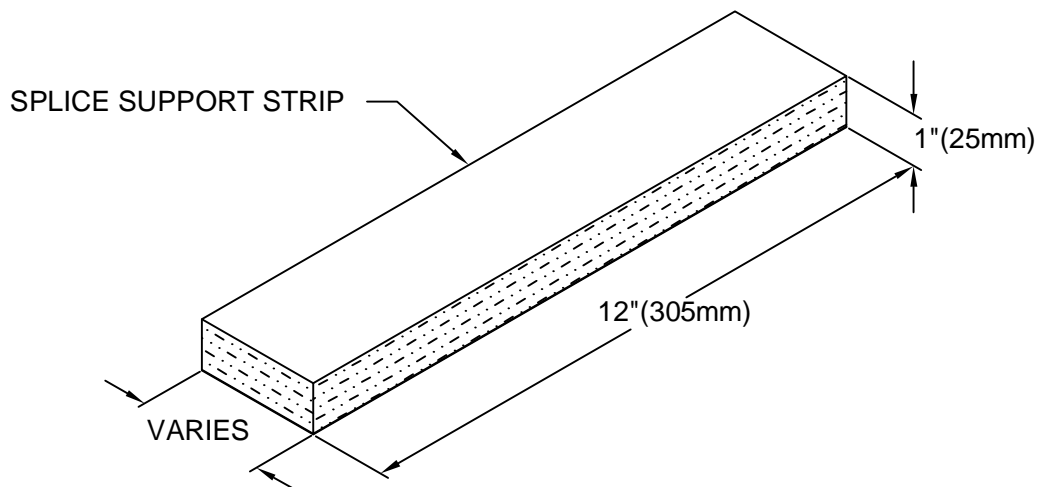
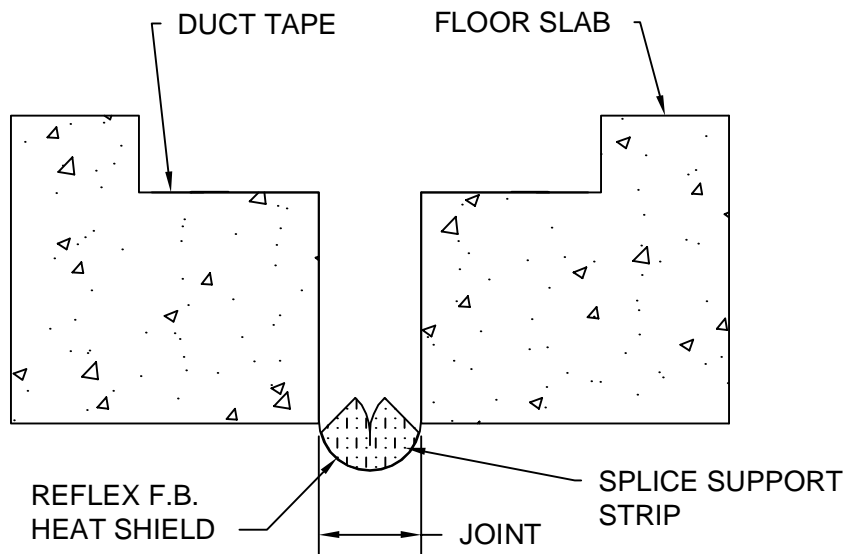

Note: Splice Support Strips are short pieces of the Insulation material that provide additional insulation at the critical Heat Shield and Insulation block splice locations.

- 6.1) At each Heat Shield splice location, spray a small amount of the C/S supplied spray adhesive on the surface of the Heat Shield, at the very bottom of the "U" shape, on each side of the splice joint.
- 6.2) Place one Splice Support Strip, printed fabric side down, in the bottom of the Heat Shield, centered over the splice.
- 6.3) Place a Splice Support Strip along side the joint, aligned with each splice in the Insulation.
- 6.4) At each Insulation splice location, spray a small amount of the C/S supplied spray adhesive on the surface of the Heat Shield, at the very bottom of the "U" shape, at each side of the splice.
- 6.5) Place one Splice Support Strip, printed fabric side down, in the bottom of the Heat Shield, centered at each Insulation splice.

STEP 7

BEGIN INSTALLATION OF THE INSULATION

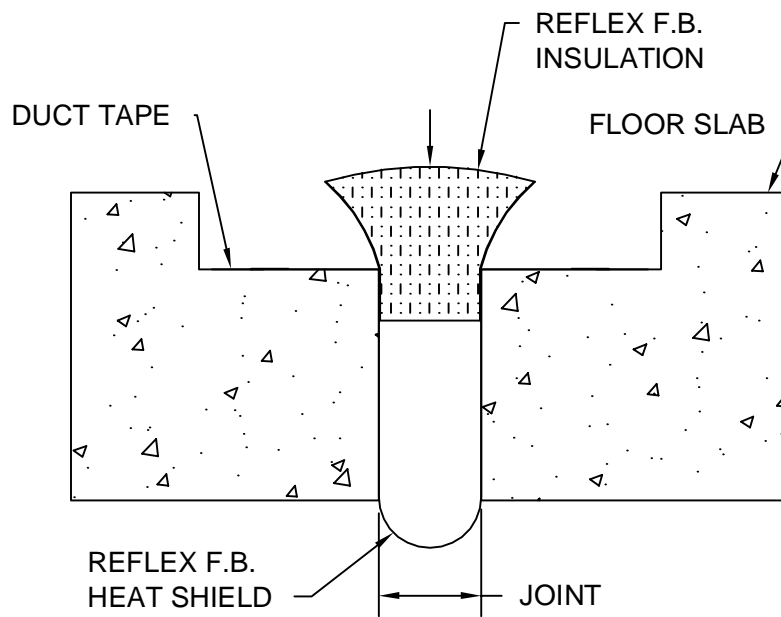
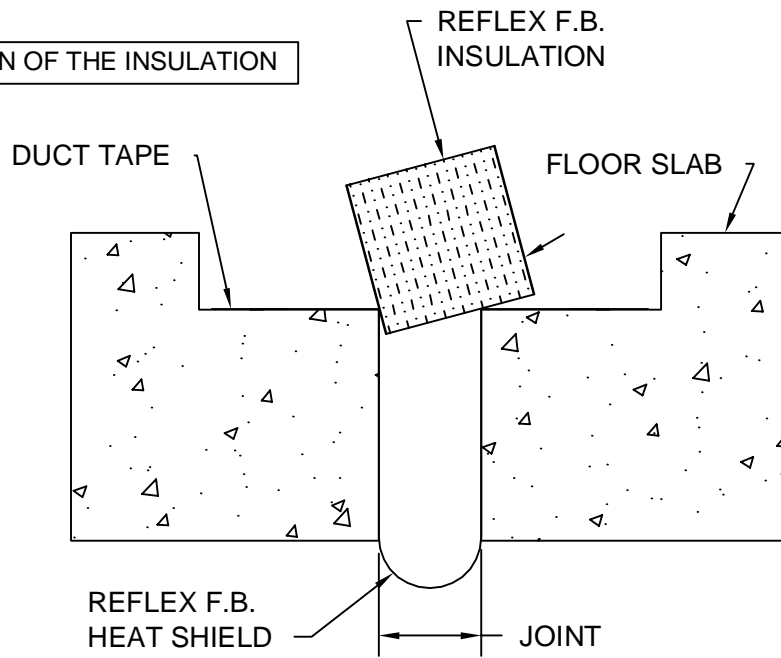

7.1) Begin installation of the Insulation by placing the Insulation over the joint. The Insulation should sit slightly off center so that one edge rests down into the joint. Position the Insulation for the entire length of the run.

7.2) Align the beginning end of the Insulation with the end of the Heat Shield.

7.3) Compress the bottom end of the Insulation and push the bottom third of the Insulation down into the joint. Continue over the full length of the Insulation until the entire length is started.

Continued next page.

STEP 7 (Cont.)

INSTALL INSULATION

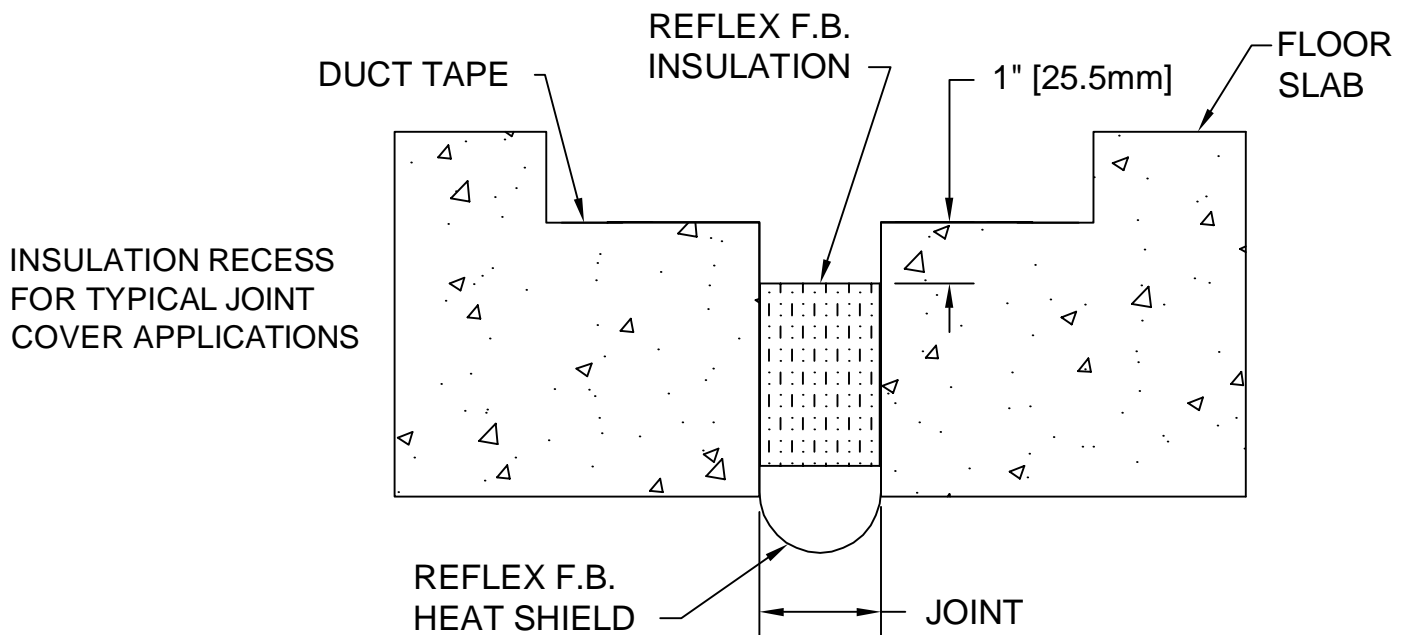
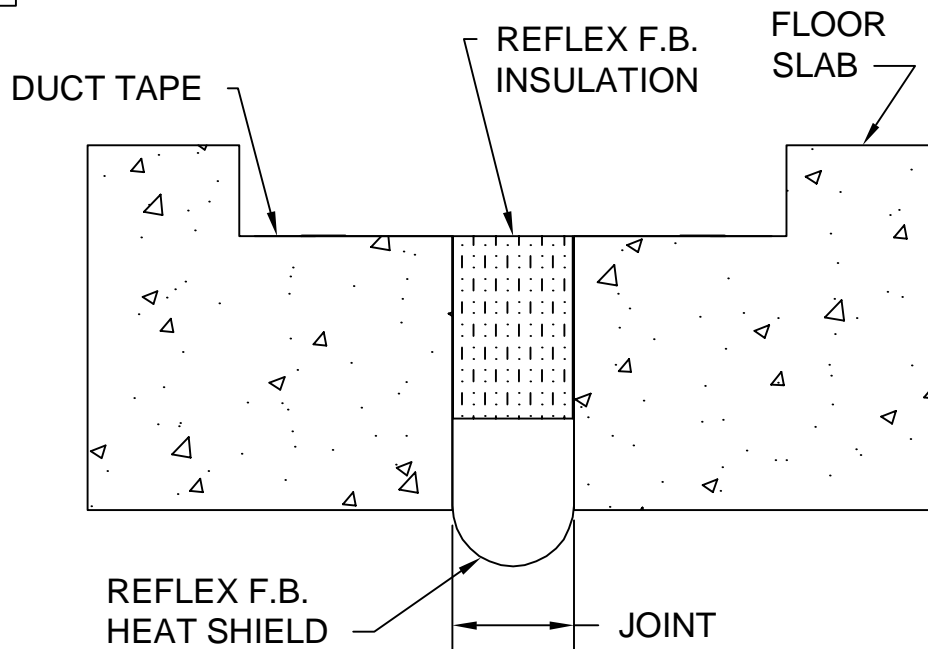

7.4) Continue to work along the full length of the run, compressing the sides of the Insulation and pushing it down lower into the joint. Note: Be careful to keep the Insulation square within the joint. Avoid having one vertical face sitting lower than the other.

7.5) Work the Insulation down until the entire length is flush with the top surface of the slab and the Insulation is square within the joint.

7.6) Finally, slide the Insulation down further until the top surface of the insulation is approx. 1" (25mm) below the top surface of the slab. Note: It may be helpful to cut a wood jig, with a 1" offset, to assist in seating the Insulation at the proper level.

STEP 8

FINISHING THE INSTALLATION

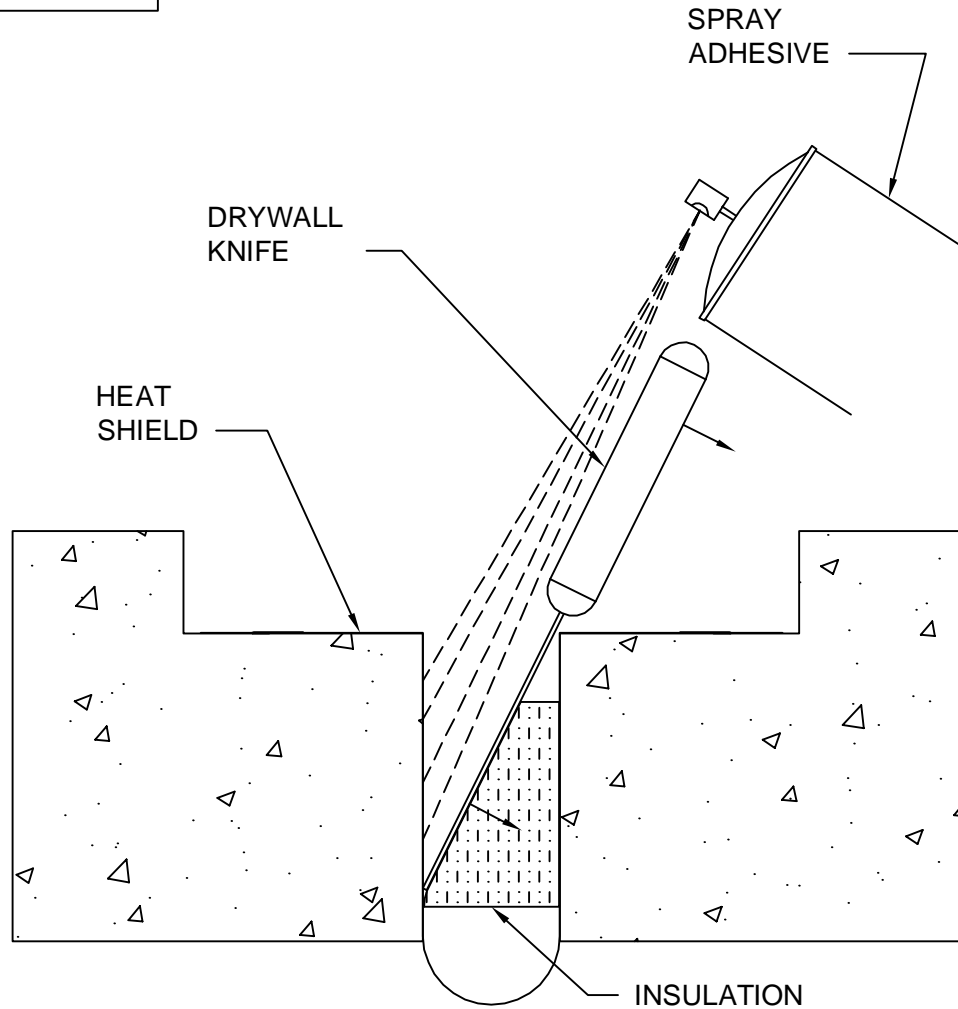

Note: To prevent the Insulation from slipping further down into the joint during years of thermal joint movement, a spray adhesive is to be applied at the indicated intervals, over the full length of the run.

- 8.1) Slide a 6" wide drywall knife between the vertical face of the Insulation and the Heat Shield.
- 8.2) Pull the handle of the knife towards the center of the joint compressing the insulation and expose a short length of the vertical face of the Heat Shield.
- 8.3) Spray a short burst of the C/S supplied Spray Adhesive onto the face of the Heat Shield.
- 8.4) Remove the drywall knife and seat the Insulation back against the Heat Shield and into the adhesive.
- 8.5) Repeat at approx. 36"(900mm) on center, along both sides of the insulation. Also apply adhesive, in the same manner, to each side of each Insulation splice.

INSTALLATION OF THIS RUN OF C/S REFLEX FLOOR FIRE BARRIER IS NOW COMPLETE. PROCEED WITH INSTALLATION OF OTHER RUNS OF FIRE BARRIER AND COMPLETE WITH INSTALLATION OF THE APPROPRIATE JOINT COVER SYSTEM. NOTE: THE FIRE BARRIERS MUST BE ANCHORED IN PLACE BY THE FRAMES AND ANCHORS OF THE JOINT COVER SYSTEM.

NOTE: These instructions indicate one method of installing the Reflex Floor Fire Barriers. After gaining some experience with the installation and materials, you may find an easier method of installation. Field conditions may also dictate deviations from these instructions. However, the final positioning of the components is to be maintained.

INSTALLATION AID

INSTALLATION ANGLES

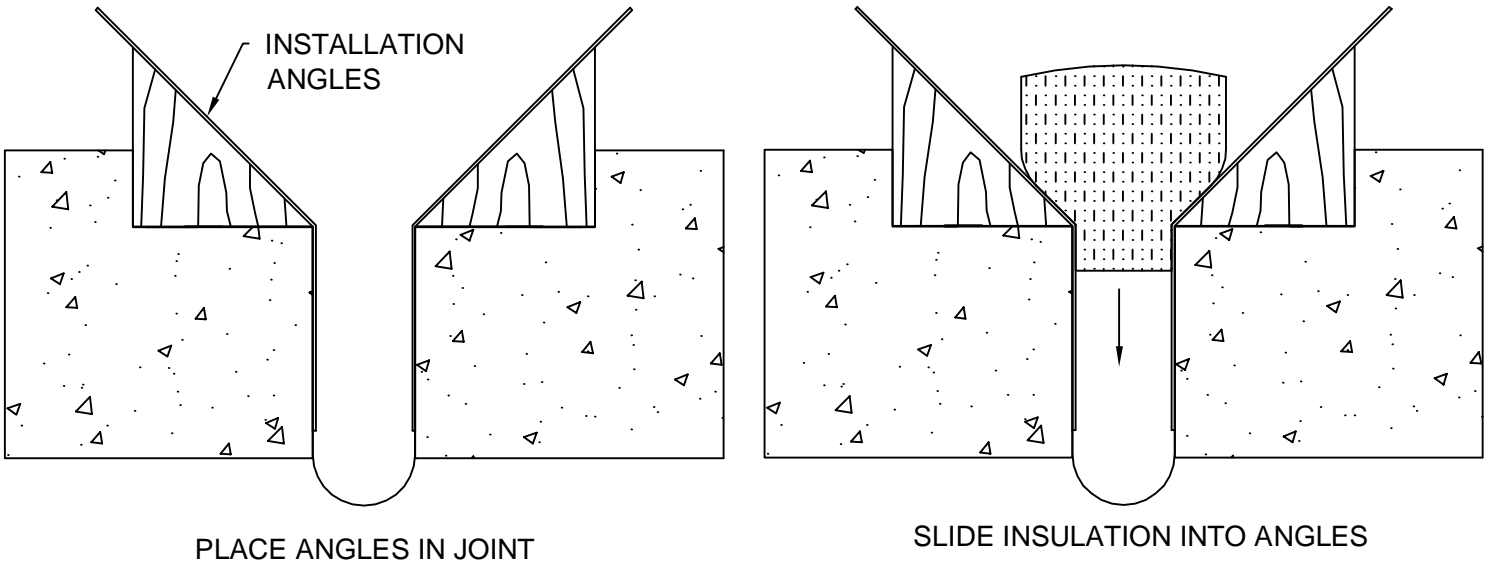
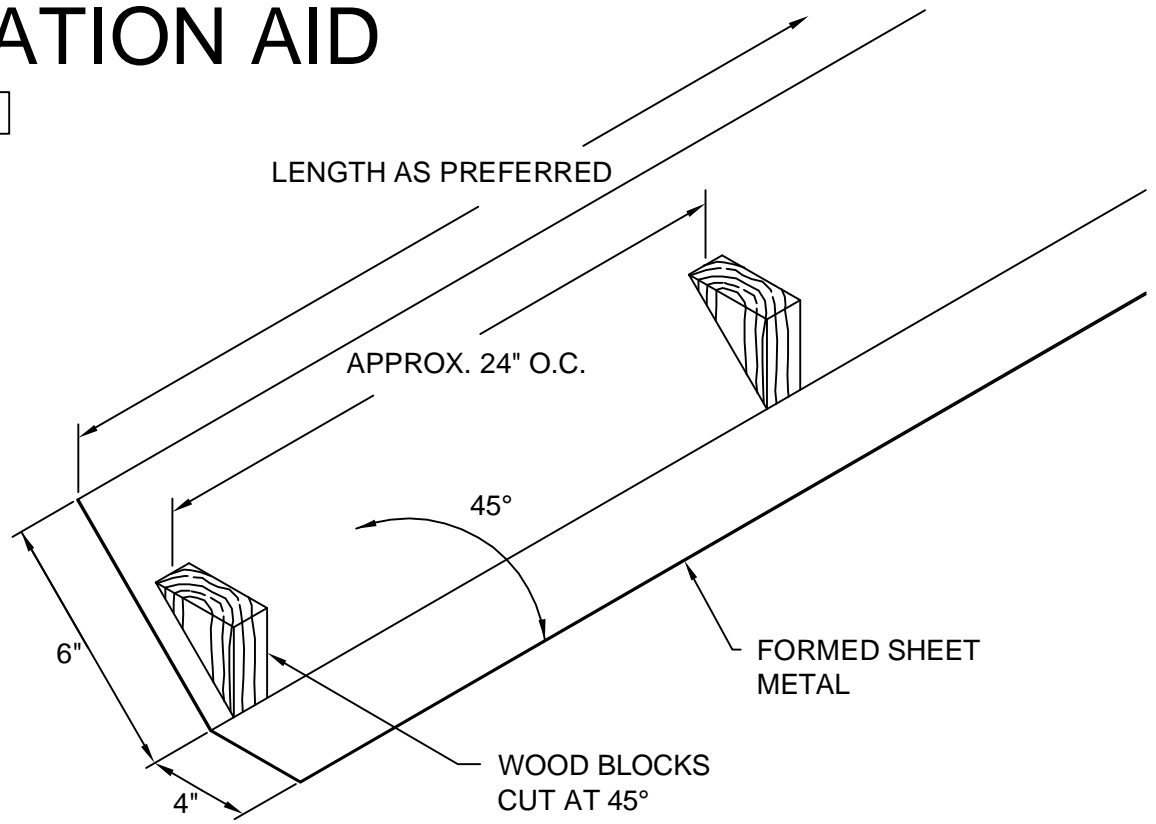

Note: To aid in installation of the Insulation, Installation Angles can be fabricated as indicated above and used to help to funnel the Insulation into the joint. Simply place one leg of the angles into the joint as shown. Position the insulation into the angles and apply inward pressure on the Insulation. Work along the full length of the insulation until the Insulation is positioned flush with the face of the slabs. Remove the Installation Angles and complete the installation by positioning the Insulation as indicated in the instructions.